



ON Semiconductor®

# NC7SB3157, FSA3157 Low-Voltage SPDT Analog Switch or 2:1 Multiplexer / De-multiplexer Bus Switch

## Features


- Useful in Both Analog and Digital Applications
- Space-Saving, SC70 6-Lead Surface Mount Package
- Ultra-Small, MicroPak™ Leadless Package
- Low On Resistance: <math><10\Omega</math> on Typical at 3.3V  $V_{CC}$
- Broad  $V_{CC}$  Operating Range: 1.65V to 5.5V
- Rail-to-Rail Signal Handling
- Power-Down, High-Impedance Control Input
- Over-Voltage Tolerance of Control Input to 7.0V
- Break-Before-Make Enable Circuitry
- 250MHz, 3dB Bandwidth

## Description

The NC7SB3157 / FSA3157 is a high-performance, single-pole / double-throw (SPDT) analog switch or 2:1 multiplexer / de-multiplexer bus switch.

The device is fabricated with advanced sub-micron CMOS technology to achieve high-speed enable and disable times and low on resistance. The break-before-make select circuitry prevents disruption of signals on the B Port due to both switches temporarily being enabled during select pin switching. The device is specified to operate over the 1.65 to 5.5V  $V_{CC}$  operating range. The control input tolerates voltages up to 5.5V, independent of the  $V_{CC}$  operating range.

## Ordering Information

Part Number	Top Mark	 Eco Status	Package Description	Packing Method
NC7SB3157P6X	B7A	RoHS	6-Lead, SC70, EIAJ SC88, 1.25mm Wide Package	3000 Units on Tape and Reel
NC7SB3157L6X	BB	RoHS	6-Lead, MicroPak 1.0mm Wide Package	5000 Units on Tape and Reel
FSA3157P6X	B7A	RoHS	6-Lead, SC70, EIAJ SC88, 1.25mm Wide Package	3000 Units on Tape and Reel
FSA3157L6X	BB	RoHS	6-Lead, MicroPak 1.0mm Wide Package	5000 Units on Tape and Reel

NC7SB3157, FSA3157 — Low-Voltage SPDT Analog Switch or 2:1 Multiplexer / De-multiplexer Bus Switch

### Logic Symbol

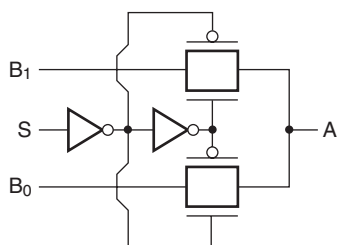
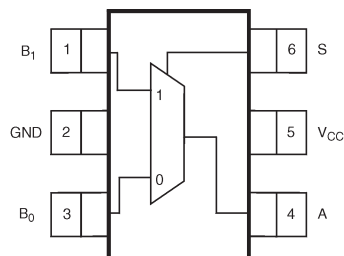


Figure 1. Logic Symbol

### Connection Diagrams



2. Pin Assignments SC70

### Analog Symbol

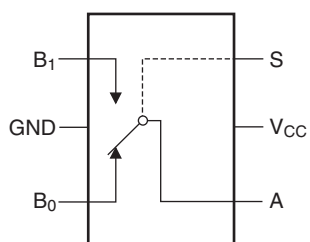


Figure 3. Analog Symbol

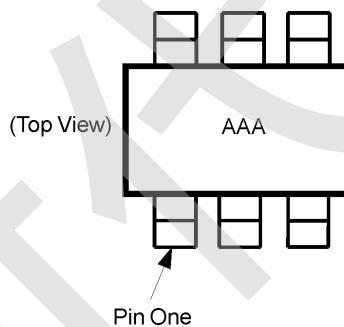


Figure 4. Pin One Orientation

### Function Table

Input (S)	Function
Logic Level Low	B <sub>0</sub> Connected to A
Logic Level High	B <sub>1</sub> Connected to A

*Note:*

Orientation of top mark determines pin one location. Read the top product code mark left to right and pin one is the lower left pin (see Figure 4).

### Pin Descriptions

Pin Names	Description
A, B <sub>0</sub> , B <sub>1</sub>	Data Ports
S	Control Input

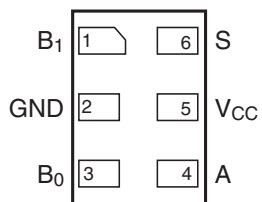


Figure 5. Pad Assignments for MicroPak™

## Absolute Maximum Ratings

Stresses exceeding the absolute maximum ratings may damage the device. The device may not function or be operable above the recommended operating conditions and stressing the parts to these levels is not recommended. In addition, extended exposure to stresses above the recommended operating conditions may affect device reliability. The absolute maximum ratings are stress ratings only.

Symbol	Parameter	Min.	Max.	Unit
$V_{CC}$	Supply Voltage	-0.5	+7.0	V
$V_S$	DC Switch Voltage <sup>(1)</sup>	-0.5	$V_{CC} + 0.5$	V
$V_{IN}$	DC Input Voltage <sup>(1)</sup>	-0.5	+7.0	V
$I_{IK}$	DC Input Diode Current at $V_{IN} < 0V$		-50	mA
$I_{OUT}$	DC Output Current		128	mA
$I_{CC}/I_{GND}$	DC $V_{CC}$ or Ground Current		$\pm 100$	mA
$T_{STG}$	Storage Temperature Range	-65	+150	°C
$T_J$	Junction Temperature Under Bias		+150	°C
$T_L$	Junction Lead Temperature (Soldering, 10 seconds)		+260	°C
MSL	Moisture Sensitivity Level (JEDEC J-STD-020A)		1	Level
$P_D$	Power Dissipation at +85°C		180	mW
ESD	Human Body Model, JESD22-A114		4000	V

**Note:**

- The input and output negative voltage ratings may be exceeded if the input and output diode current ratings are observed.

## Recommended Operating Conditions

The Recommended Operating Conditions table defines the conditions for actual device operation. Recommended operating conditions are specified to ensure optimal performance to the datasheet specifications. ON Semiconductor does not recommend exceeding them or designing to absolute maximum ratings.

Symbol	Parameter	Min.	Max.	Unit	
$V_{CC}$	Supply Voltage Operating	1.65	5.50	V	
$V_{IN}$	Control Input Voltage <sup>(2)</sup>	0	$V_{CC}$	V	
$V_{IN}$	Switch Input Voltage <sup>(2)</sup>	0	$V_{CC}$	V	
$V_{OUT}$	Output Voltage <sup>(2)</sup>	0	$V_{CC}$	V	
$T_A$	Operating Temperature	-40	+85	°C	
$t_r, t_f$	Input Rise and Fall Time	Control Input $V_{CC} = 2.3V-3.6V$	0	10	ns/V
		Control Input $V_{CC} = 4.5V-5.5V$	0	5	ns/V
$\theta_{JA}$	Thermal Resistance, SC70		270	°C/W	

**Note:**

- Control input must be held HIGH or LOW; it must not float.

## DC Electrical Characteristics

Symbol	Parameter	Conditions	V <sub>CC</sub> (V)	T <sub>A</sub> = +25°C			T <sub>A</sub> = -40°C to +85°C		Units
				Min.	Typ.	Max.	Min.	Max.	
V <sub>IH</sub>	High Level Input Voltage		1.65 – 1.95	0.75 V <sub>CC</sub>			0.75 V <sub>CC</sub>		V
			2.3 – 5.5	0.7 V <sub>CC</sub>			0.7 V <sub>CC</sub>		
V <sub>IL</sub>	Low Level Input Voltage		1.65 – 1.95			0.25 V <sub>CC</sub>		0.25 V <sub>CC</sub>	V
			2.3 – 5.5			0.3 V <sub>CC</sub>		0.3 V <sub>CC</sub>	
I <sub>IN</sub>	Input Leakage Current	0 ≤ V <sub>IN</sub> ≤ 5.5V	0 – 5.5		±0.05	±0.1		±1	μA
I <sub>OFF</sub>	Off State Leakage Current	0 ≤ A, B ≤ V <sub>CC</sub>	1.65 – 5.5		±0.05	±0.1		±1	μA
R <sub>ON</sub>	Switch On Resistance <sup>(3)</sup>	V <sub>IN</sub> = 0V, I <sub>O</sub> = 30mA	4.5		3.0	7.0		7.0	Ω
		V <sub>IN</sub> = 2.4V, I <sub>O</sub> = -30mA			5.0	12.0		12.0	
		V <sub>IN</sub> = 4.5V, I <sub>O</sub> = -30mA		7.0	15.0		15.0		
		V <sub>IN</sub> = 0V, I <sub>O</sub> = 24mA	3.0		4.0	9.0		9.0	
		V <sub>IN</sub> = 3V, I <sub>O</sub> = -24mA			10.0	20.0		20.0	
		V <sub>IN</sub> = 0V, I <sub>O</sub> = 8mA	2.3		5.0	12.0		12.0	
		V <sub>IN</sub> = 2.3V, I <sub>O</sub> = -8mA			13.0	30.0		30.0	
		V <sub>IN</sub> = 0V, I <sub>O</sub> = 4mA	1.65		6.5	20.0		20.0	
V <sub>IN</sub> = 1.65V, I <sub>O</sub> = -4mA		17.0		50.0		50.0			
I <sub>CC</sub>	Quiescent Supply Current; All Channels On or Off	V <sub>IN</sub> = V <sub>CC</sub> or GND I <sub>OUT</sub> = 0	5.5			1		10	μA
	Analog Signal Range		V <sub>CC</sub>	0		V <sub>CC</sub>	0	V <sub>CC</sub>	V
R <sub>RANGE</sub>	On Resistance Over Signal Range <sup>(3, 7)</sup>	I <sub>A</sub> = -30mA, 0 ≤ V <sub>Bn</sub> ≤ V <sub>CC</sub>	4.5					25.0	Ω
		I <sub>A</sub> = -24mA, 0 ≤ V <sub>Bn</sub> ≤ V <sub>CC</sub>	3.0					50.0	
		I <sub>A</sub> = -8mA, 0 ≤ V <sub>Bn</sub> ≤ V <sub>CC</sub>	2.3					100	
		I <sub>A</sub> = -4mA, 0 ≤ V <sub>Bn</sub> ≤ V <sub>CC</sub>	1.65					300	
ΔR <sub>ON</sub>	On Resistance Match Between-Channels <sup>(3, 4, 5)</sup>	I <sub>A</sub> = -30mA, V <sub>Bn</sub> = 3.15	4.5		0.15				Ω
		I <sub>A</sub> = -24mA, V <sub>Bn</sub> = 2.1	3.0		0.2				
		I <sub>A</sub> = -8mA, V <sub>Bn</sub> = 1.6	2.3		0.5				
		I <sub>A</sub> = -4mA, V <sub>Bn</sub> = 1.15	1.65		0.50				
R <sub>flat</sub>	On Resistance Flatness <sup>(3, 4, 6)</sup>	I <sub>A</sub> = -30mA, 0 ≤ V <sub>Bn</sub> ≤ V <sub>CC</sub>	5.0		6.0				Ω
		I <sub>A</sub> = -24mA, 0 ≤ V <sub>Bn</sub> ≤ V <sub>CC</sub>	3.3		12.0				
		I <sub>A</sub> = -8mA, 0 ≤ V <sub>Bn</sub> ≤ V <sub>CC</sub>	2.5		28.0				
		I <sub>A</sub> = -4mA, 0 ≤ V <sub>Bn</sub> ≤ V <sub>CC</sub>	1.8		125				

### Notes:

- Measured by the voltage drop between A and B pins at the indicated current through the switch. On resistance is determined by the lower of the voltages on the two (A or B Ports).
- Parameter is characterized, but not tested in production.
- ΔR<sub>ON</sub> = R<sub>ON</sub> max – R<sub>ON</sub> minimum measured at identical V<sub>CC</sub>, temperature, and voltage levels.
- Flatness is defined as the difference between the maximum and minimum value of on resistance over the specified range of conditions.
- Guaranteed by design.

## AC Electrical Characteristics

Symbol	Parameter	Conditions	V <sub>CC</sub> (V)	T <sub>A</sub> = +25°C			T <sub>A</sub> = -40°C to +85°C		Units	Figure Number
				Min.	Typ.	Max.	Min.	Max.		
t <sub>PHL</sub> , t <sub>PLH</sub>	Propagation Delay Bus-to-Bus <sup>(8)</sup>	V <sub>I</sub> = OPEN	1.65 – 1.95			3.5		3.5	ns	Figure 12 Figure 13
			2.3 – 2.7			1.2		1.2		
			3.0 – 3.6			0.8		0.8		
			4.5 – 5.5			0.3		0.3		
t <sub>PZL</sub> , t <sub>PZH</sub>	Output Enable Time Turn-On Time (A to B <sub>n</sub> )	V <sub>I</sub> = 2 x V <sub>CC</sub> for t <sub>PZL</sub> V <sub>I</sub> = 0V for t <sub>PZH</sub>	1.65 – 1.95	7.0		23.0	7.0	24.0	ns	Figure 12 Figure 13
			2.3 – 2.7	3.5		13.0	3.5	14.0		
			3.0 – 3.6	2.5		6.9	2.5	7.6		
			4.5 – 5.5	1.7		5.2	1.7	5.7		
t <sub>PLZ</sub> , t <sub>PHZ</sub>	Output Disable Time Turn-Off Time (A Port to B Port)	V <sub>I</sub> = 2 x V <sub>CC</sub> for t <sub>PLZ</sub> V <sub>I</sub> = 0V for t <sub>PHZ</sub>	1.65 – 1.95	3.0		12.5	3.0	13.0	ns	Figure 12 Figure 13
			2.3 – 2.7	2.0		7.0	2.0	7.5		
			3.0 – 3.6	1.5		5.0	1.5	5.3		
			4.5 – 5.5	0.8		3.5	0.8	3.8		
t <sub>B-M</sub>	Break-Before-Make Time <sup>(9)</sup>		1.65 – 1.95	0.5			0.5		ns	Figure 14
			2.3 – 2.7	0.5			0.5			
			3.0 – 3.6	0.5			0.5			
			4.5 – 5.5	0.5			0.5			
Q	Charge Injection <sup>(9)</sup>	C <sub>L</sub> = 0.1nF, V <sub>GEN</sub> = 0V,	5.0		7.0			pC	Figure 15	
		R <sub>GEN</sub> = 0Ω	3.3		3.0					
OIRR	Off Isolation <sup>(10)</sup>	R <sub>L</sub> = 50Ω, f = 10MHz	1.65 – 5.5		-57.0			dB	Figure 16	
Xtalk	Crosstalk	R <sub>L</sub> = 50Ω, f = 10MHz	1.65 – 5.5		-54.0			dB	Figure 17	
BW	-3dB Bandwidth	R <sub>L</sub> = 50Ω	1.65 – 5.5		250			MHz	Figure 20	
THD	Total Harmonic Distortion <sup>(9)</sup>	R <sub>L</sub> = 600Ω, 0.5 V <sub>PP</sub> , f = 600 Hz to 20 KHz	5.0		.011			%		

### Notes:

8. This parameter is guaranteed by design but not tested. The bus switch contributes no propagation delay other than the RC delay of the on resistance of the switch and the 50pF load capacitance, when driven by an ideal voltage source (zero output impedance).
9. Guaranteed by design.
10. Off Isolation = 20 log<sub>10</sub> [V<sub>A</sub> / V<sub>Bn</sub>].

### Capacitance

T<sub>A</sub> = +25°C, f = 1MHz. Capacitance is characterized, but not tested in production.

Symbol	Parameter	Conditions	Typ.	Max.	Units	Figure Number
C <sub>IN</sub>	Control Pin Input Capacitance	V <sub>CC</sub> = 0V	2.3		pF	
C <sub>IO-B</sub>	B Port Off Capacitance	V <sub>CC</sub> = 5.0V	6.5		pF	Figure 18
C <sub>IOA-ON</sub>	A Port Capacitance When Switch Is Enabled	V <sub>CC</sub> = 5.0V	18.5		pF	Figure 19

## Typical Characteristics

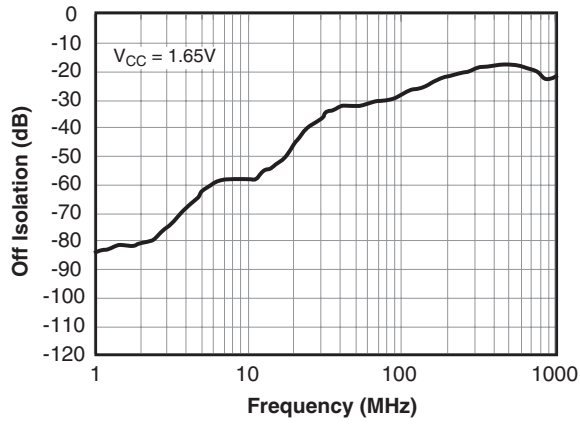


Figure 6. Off Isolation,  $V_{CC} = 1.65V$

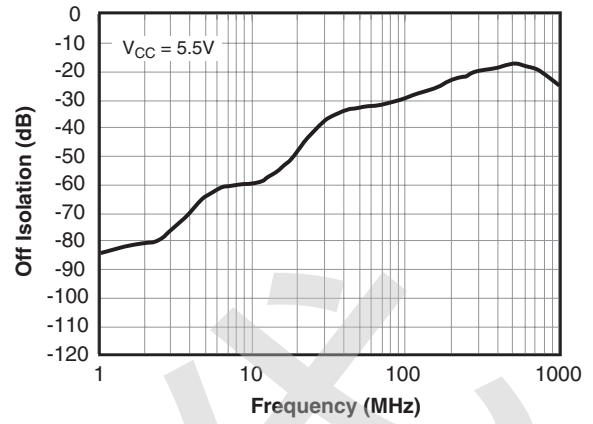


Figure 7. Off Isolation,  $V_{CC} = 5.5V$

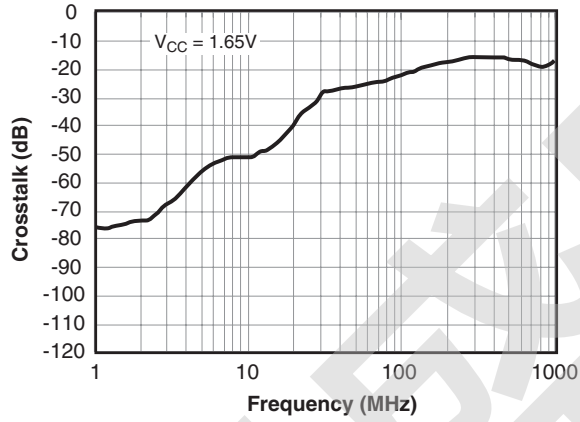


Figure 8. Crosstalk,  $V_{CC} = 1.65V$

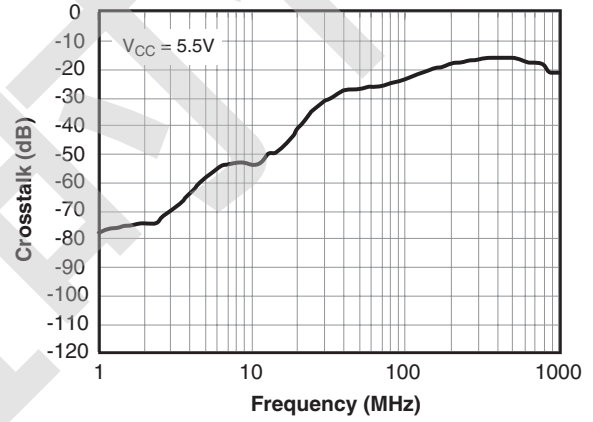


Figure 9. Crosstalk,  $V_{CC} = 5.5V$

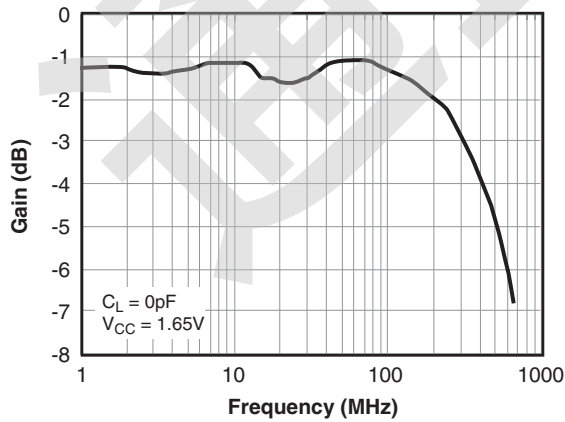


Figure 10. Bandwidth,  $V_{CC} = 1.65V$

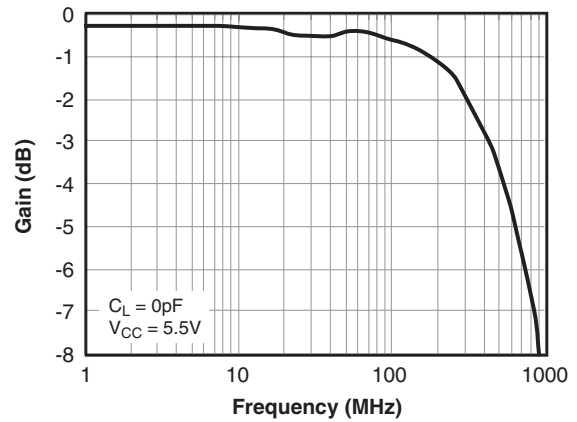
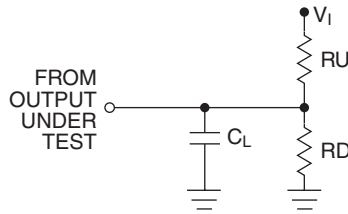


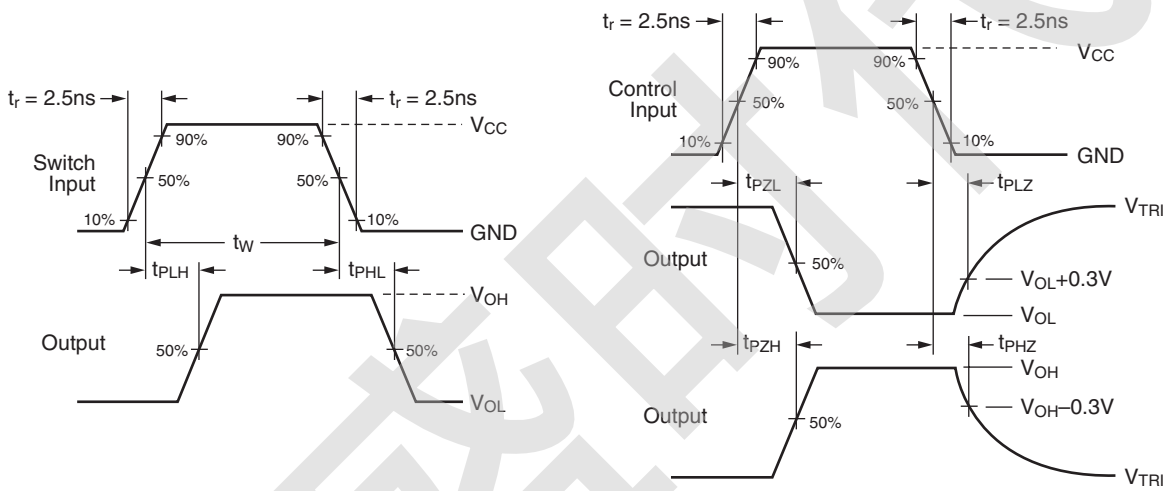
Figure 11. Bandwidth,  $V_{CC} = 5.5V$

## AC Loading and Waveforms

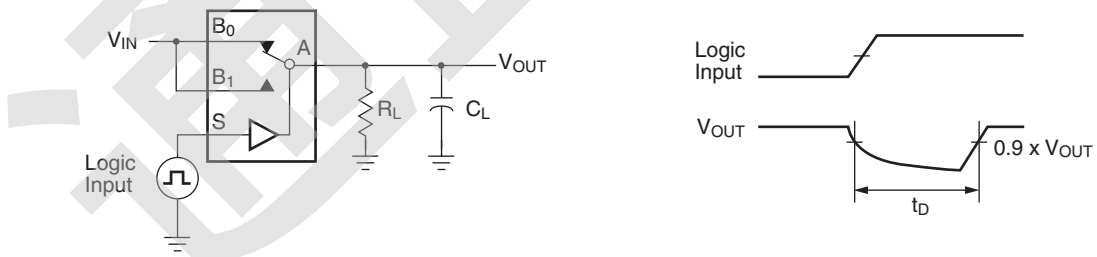


**Notes:**  
 Input driven by 50Ω source terminated in 50Ω  
 $C_L$  includes load and stray capacitance  
 Input PRR = 1.0 MHz;  $t_W = 500$  ns

**Figure 12. AC Test Circuit**

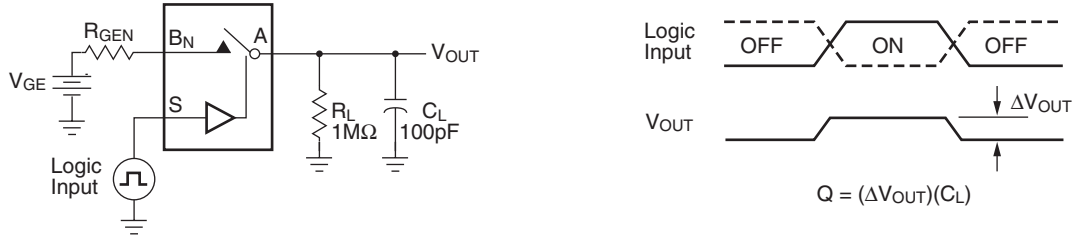


**Figure 13. AC Waveforms**

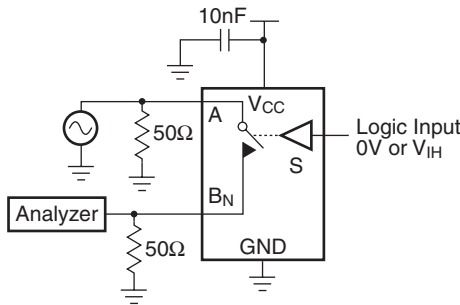


**Figure 14. Break-Before-Make Interval Timing**

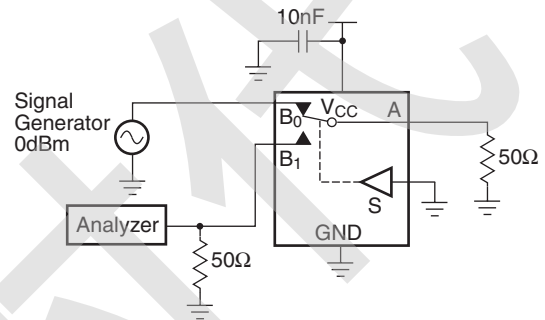
**AC Loading and Waveforms** (continued)



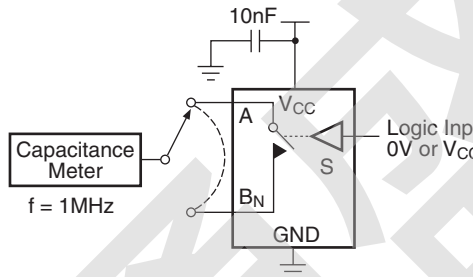
**Figure 15. Charge Injection Test**



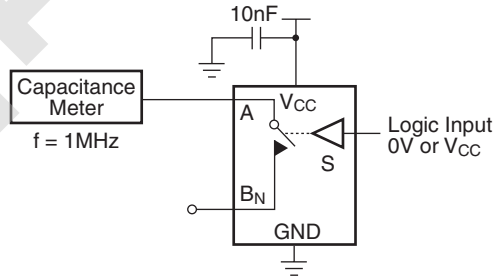
**Figure 16. Off Isolation**



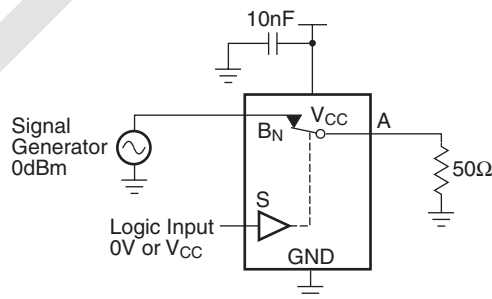
**Figure 17. Crosstalk**



**Figure 18. Channel Off Capacitance**



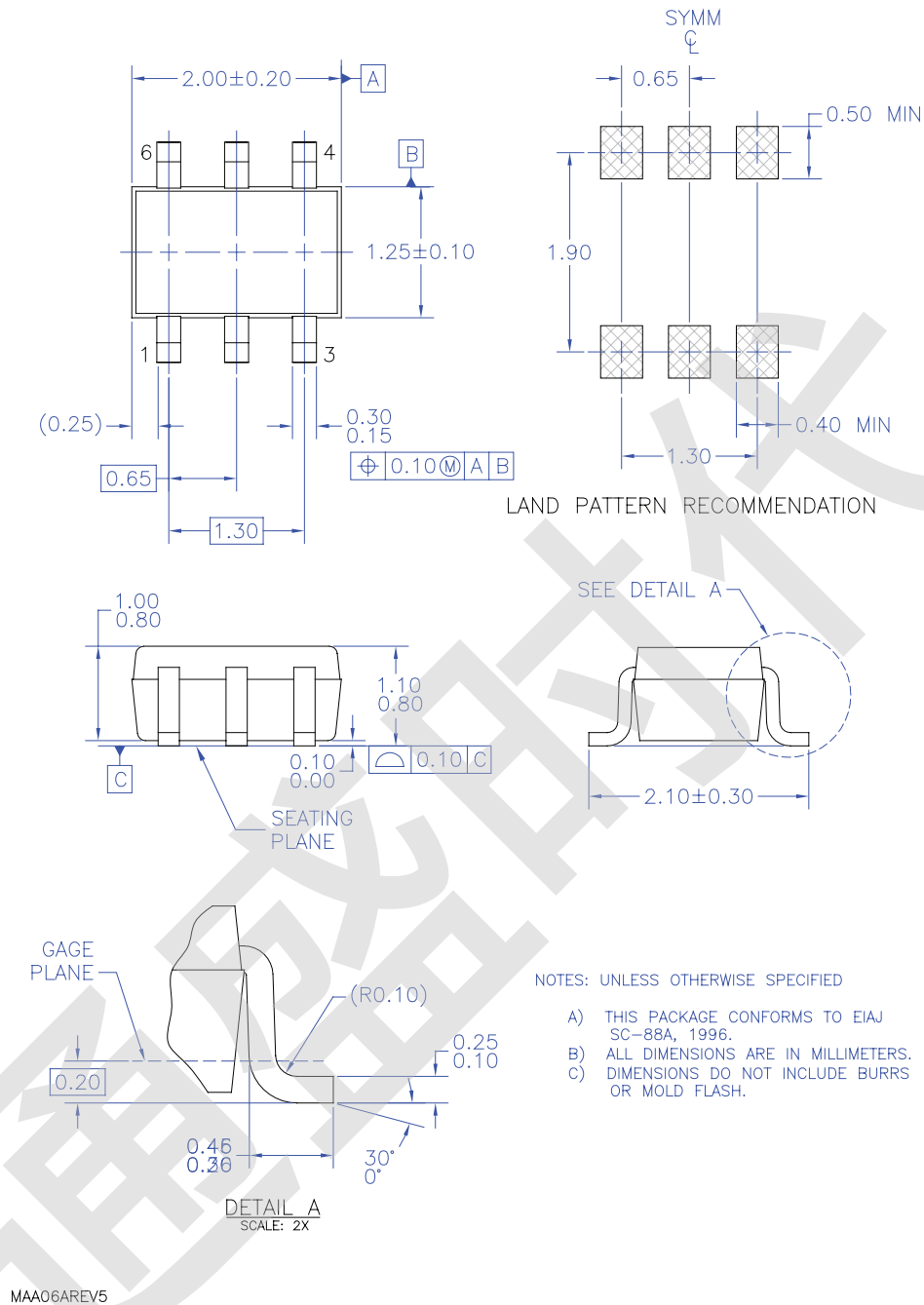
**Figure 19. Channel On Capacitance**



**Figure 20. Bandwidth**



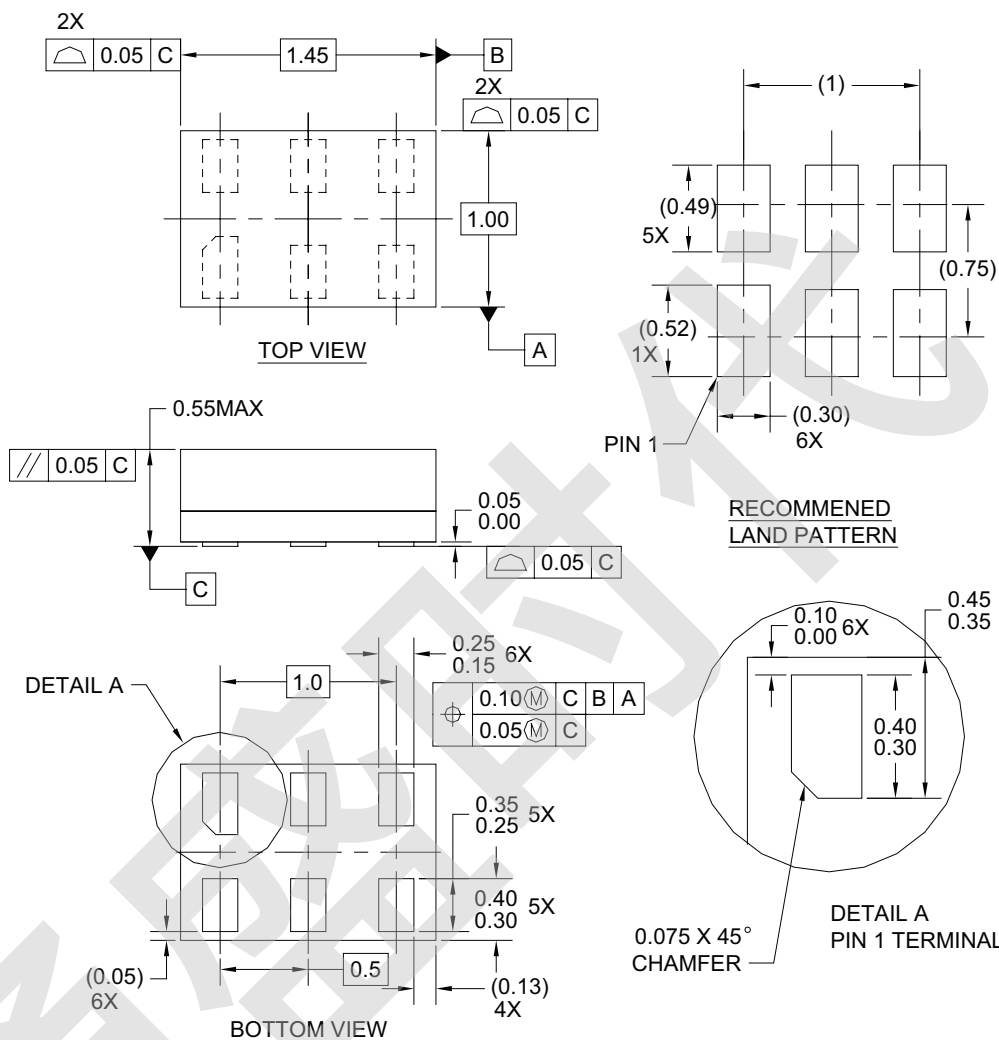
## Physical Dimensions



**Figure 21. 6-Lead, SC70, EIAJ SC88, 1.25mm Wide Package**

Package drawings are provided as a service to customers considering ON Semiconductor components. Drawings may change in any manner without notice. Please note the revision and/or date on the drawing and contact a ON Semiconductor representative to verify or obtain the most recent revision. Package specifications do not expand the terms of ON Semiconductor's worldwide terms and conditions, specifically the warranty therein, which covers ON Semiconductor products.

## Physical Dimensions



**Notes:**

1. CONFORMS TO JEDEC STANDARD M0-252 VARIATION UAAD
2. DIMENSIONS ARE IN MILLIMETERS
3. DRAWING CONFORMS TO ASME Y14.5M-1994

MAC06AREVC

### 6-Lead, MicroPak™ 1.0mm Wide Package

Package drawings are provided as a service to customers considering ON Semiconductor components. Drawings may change in any manner without notice. Please note the revision and/or date on the drawing and contact a ON Semiconductor representative to verify or obtain the most recent revision. Package specifications do not expand the terms of ON Semiconductor's worldwide terms and conditions, specifically the warranty therein, which covers ON Semiconductor products.