



# SLU5N65SV / SLD5N65SV

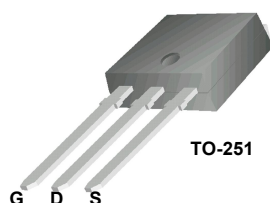
## 650V N-Channel MOSFET

### General Description

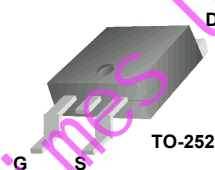
This Power MOSFET is produced using Msemitec's advanced planar stripe DMOS technology. This advanced technology has been especially tailored to minimize on-state resistance, provide superior switching performance, and withstand high energy pulse in the avalanche and commutation mode. These devices are well suited for high efficiency switched mode power supplies, active power factor correction based on half bridge topology.

### Features

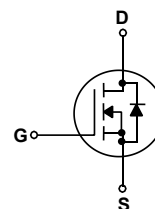
- 5A, 650V,  $R_{DS(on)Type}=2.2\Omega@V_{GS}=10V$
- Low gate charge ( typical 13nC)
- High ruggedness
- Fast switching
- 100% avalanche tested
- Improved dv/dt capability



TO-251



TO-252



### Absolute Maximum Ratings $T_C = 25^\circ\text{C}$ unless otherwise noted

Symbol	Parameter	SLU5N65SV	SLD5N65SV	Units
$V_{DSS}$	Drain-Source Voltage	650		V
$I_D$	Drain Current	- Continuous ( $T_C = 25^\circ\text{C}$ )	5	A
		- Continuous ( $T_C = 100^\circ\text{C}$ )	3	A
$I_{DM}$	Drain Current Pulsed (Note 1)	10		A
$V_{GSS}$	Gate-Source Voltage	$\pm 30$		V
EAS	Single Pulsed Avalanche Energy (Note 2)	173		mJ
$I_{AR}$	Avalanche Current (Note 1)	4		A
$E_{AR}$	Repetitive Avalanche Energy (Note 1)	3.5		mJ
dv/dt	Peak Diode Recovery dv/dt (Note 3)	2.1		V/ns
$P_D$	Power Dissipation ( $T_C = 25^\circ\text{C}$ ) - Derate above $25^\circ\text{C}$	-	32	W
		-	0.256	W/ $^\circ\text{C}$
$T_J, T_{STG}$	Operating and Storage Temperature Range	-55 to +150		$^\circ\text{C}$
$T_L$	Maximum lead temperature for soldering purposes, 1/8" from case for 5 seconds	300		$^\circ\text{C}$

### Thermal Characteristics

Symbol	Parameter	Max		Units
		SLU5N65SV	SLD5N65SV	
$R_{\theta JC}$	Thermal Resistance, Junction-to-Case	-	3.9	$^\circ\text{C}/\text{W}$
$R_{\theta JA}$	Thermal Resistance, Junction-to-Ambient	62.5	62.5	$^\circ\text{C}/\text{W}$

## Package Marking

Part Number	Top Marking	Package	Packing Method	MOQ	QTY
SLU5N65SV	SLU5N65SV	TO-251	Tube	3750	18750
SLD5N65SV	SLD5N65SV	TO-252	Tape & Reel	2500	25000

## Electrical Characteristics

$T_C = 25^\circ\text{C}$  unless otherwise noted

Symbol	Parameter	Test Conditions	Min	Typ	Max	Units
--------	-----------	-----------------	-----	-----	-----	-------

### Off Characteristics

$BV_{DSS}$	Drain-Source Breakdown Voltage	$V_{GS} = 0\text{ V}, I_D = 250\text{ }\mu\text{A}$	650	--	--	V
$\Delta BV_{DSS} / \Delta T_J$	Breakdown Voltage Temperature Coefficient	$I_D = 250\text{ }\mu\text{A}$ , Referenced to $25^\circ\text{C}$	--	-	--	$V/^\circ\text{C}$
$I_{DSS}$	Zero Gate Voltage Drain Current	$V_{DS} = 650\text{ V}, V_{GS} = 0\text{ V}$	--	--	10	$\mu\text{A}$
		$V_{DS} = 520\text{ V}, T_C = 125^\circ\text{C}$	--	--	100	$\mu\text{A}$
$I_{GSSF}$	Gate-Body Leakage Current, Forward	$V_{GS} = 30\text{ V}, V_{DS} = 0\text{ V}$	--	--	100	nA
$I_{GSSR}$	Gate-Body Leakage Current, Reverse	$V_{GS} = -30\text{ V}, V_{DS} = 0\text{ V}$	--	--	-100	nA

### On Characteristics

$V_{GS(th)}$	Gate Threshold Voltage	$V_{DS} = V_{GS}, I_D = 250\text{ }\mu\text{A}$	2.0	--	4.0	V
$R_{DS(on)}$	Static Drain-Source On-Resistance	$V_{GS} = 10\text{ V}, I_D = 2\text{ A}$	--	2.2	2.6	$\Omega$
$g_{FS}$	Forward Transconductance	$V_{DS} = 40\text{ V}, I_D = 2\text{ A}$ (Note 4)	--	2.5	--	S

### Dynamic Characteristics

$C_{iss}$	Input Capacitance	$V_{DS} = 25\text{ V}, V_{GS} = 0\text{ V}, f = 1.0\text{ MHz}$	--	585	--	pF
$C_{oss}$	Output Capacitance		--	46.8	--	pF
$C_{riss}$	Reverse Transfer Capacitance		--	2.5	--	pF

### Switching Characteristics

$t_{d(on)}$	Turn-On Delay Time	$V_{DS} = 100\text{ V}, V_{GS} = 10\text{ V}, I_D = 4\text{ A}, R_G = 25\text{ }\Omega$ (Note 4, 5)	--	7	--	ns
$t_r$	Turn-On Rise Time		--	16	--	ns
$t_{d(off)}$	Turn-Off Delay Time		--	36	--	ns
$t_f$	Turn-Off Fall Time		--	22	--	ns
$Q_g$	Total Gate Charge	$V_{DS} = 520\text{ V}, I_D = 4\text{ A}, V_{GS} = 10\text{ V}$ (Note 4, 5)	--	13	--	nC
$Q_{gs}$	Gate-Source Charge		--	4	--	nC
$Q_{gd}$	Gate-Drain Charge		--	2.2	--	nC

### Drain Diode Characteristics and Maximum Ratings

$I_S$	Maximum Continuous Drain-Source Diode Forward Current	--	--	5	A	
$I_{SM}$	Maximum Pulsed Drain-Source Diode Forward Current	--	--	10	A	
$V_{SD}$	Drain-Source Diode Forward Voltage	$V_{GS} = 0\text{ V}, I_S = 5\text{ A}$	--	--	1.4	V
$t_{rr}$	Reverse Recovery Time	$V_{GS} = 0\text{ V}, I_S = 5\text{ A}$	--	250	--	ns
$Q_{rr}$	Reverse Recovery Charge	$di_F / dt = 100\text{ A}/\mu\text{s}$ (Note 4)	--	4.5	--	$\mu\text{C}$

#### Notes:

1. Repetitive Rating : Pulse width limited by maximum junction temperature
2.  $L = 30\text{ mH}, I_{AS} = 3.4\text{ A}, V_{DD} = 50\text{ V}, R_G = 25\text{ }\Omega$ , Starting  $T_J = 25^\circ\text{C}$
3.  $I_{SD} \leq 4\text{ A}, di/dt \leq 200\text{ A}/\mu\text{s}, V_{DD} \leq BV_{DSS}$ , Starting  $T_J = 25^\circ\text{C}$
4. Pulse Test : Pulse width  $\leq 300\text{ }\mu\text{s}$ , Duty cycle  $\leq 2\%$
5. Essentially independent of operating temperature

### N- Channel Typical Characteristics

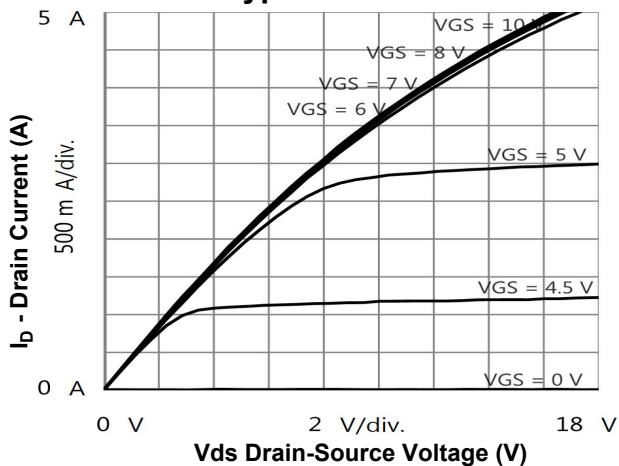


Figure 1. On-Region Characteristics

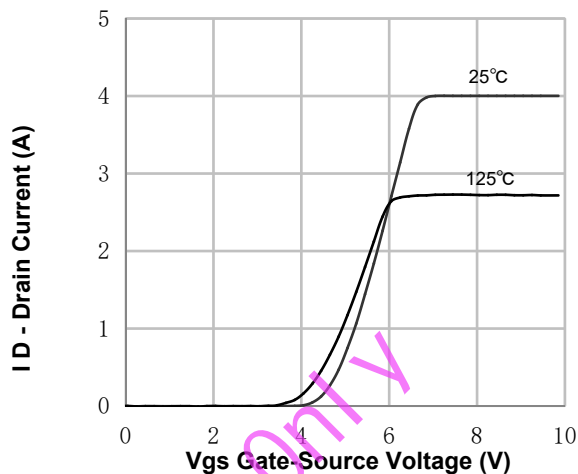


Figure 2. Transfer Characteristics

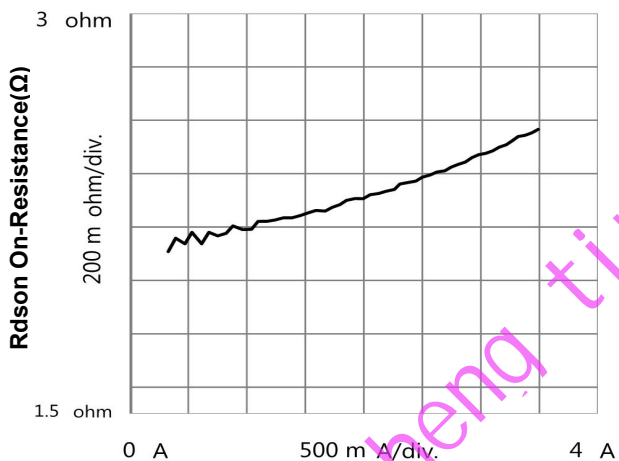


Figure 3. On-Resistance Variation vs Drain Current and Gate Voltage

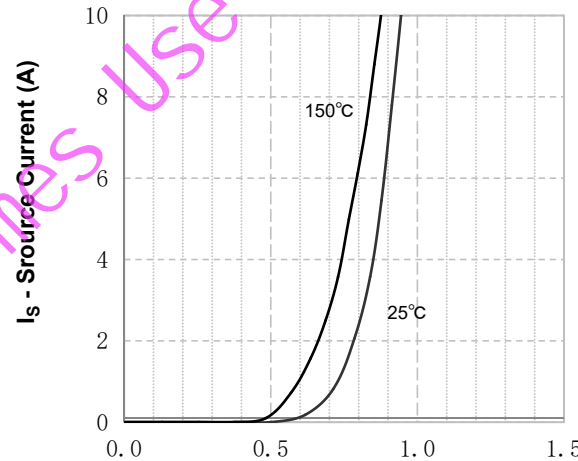


Figure 4. Source Current vs Source-Drain Voltage

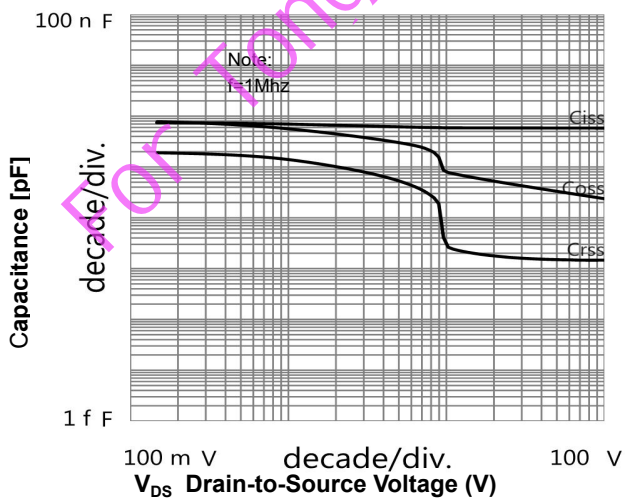


Figure 5.1 Capacitance Characteristics

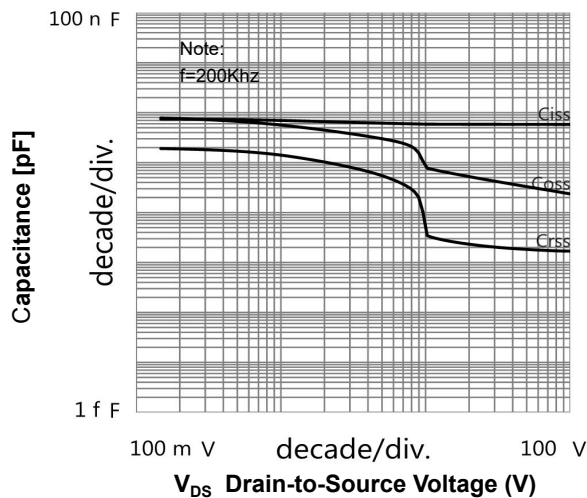
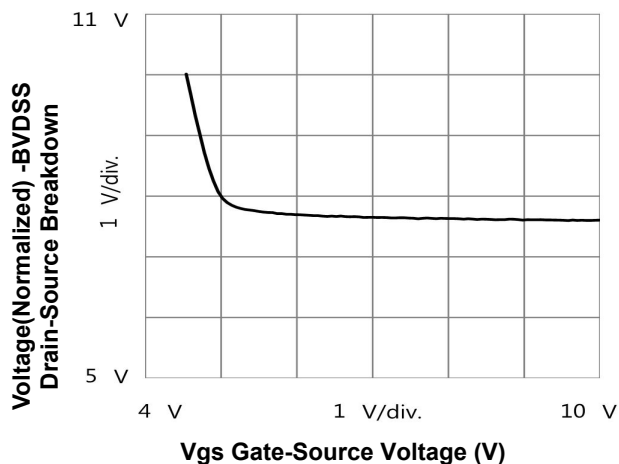
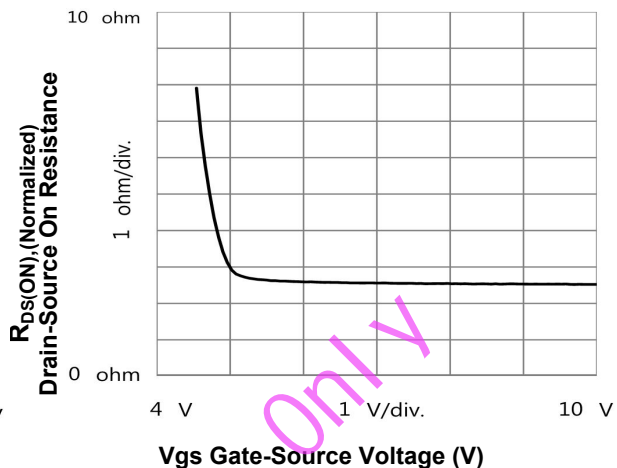


Figure 5.2 Capacitance Characteristics

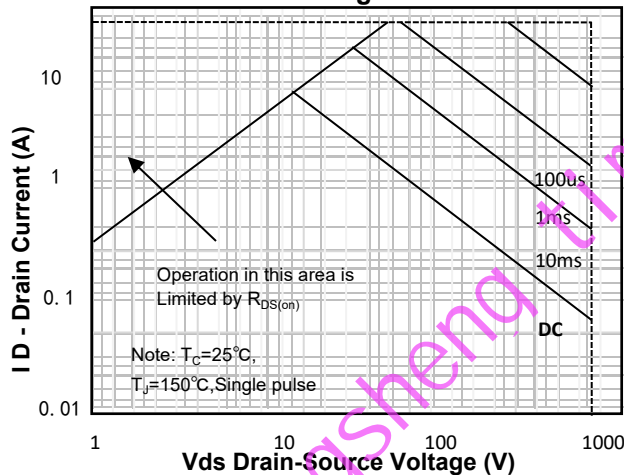
### N- Channel Typical Characteristics (Continued)



**Figure 7. Breakdown Voltage Variation vs Gate-Source Voltage**

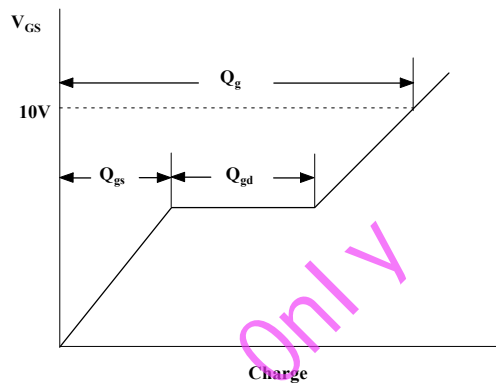
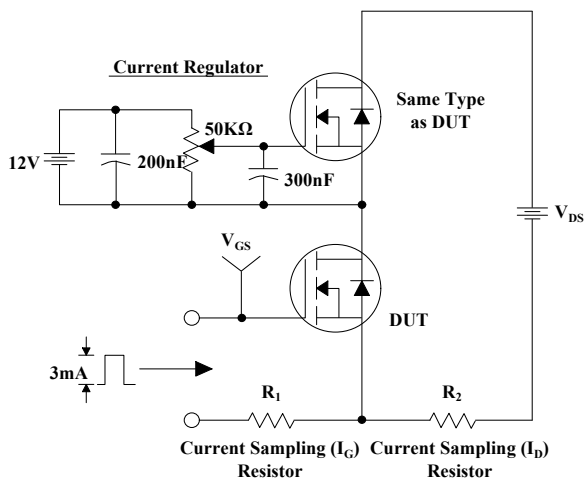


**Figure 8. On-Resistance Variation vs Gate-Source Voltage**

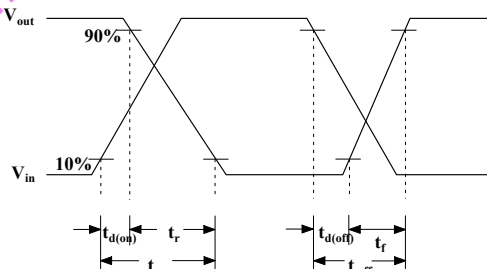
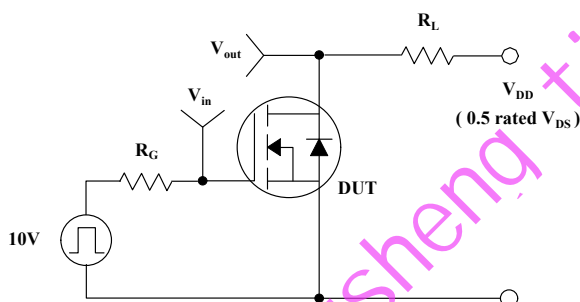


**Figure 9. Maximum Safe Operating Area**

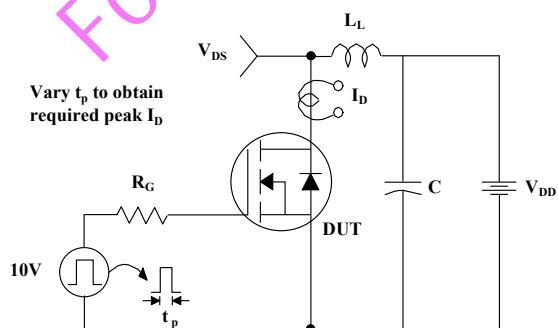
### Gate Charge Test Circuit & Waveform



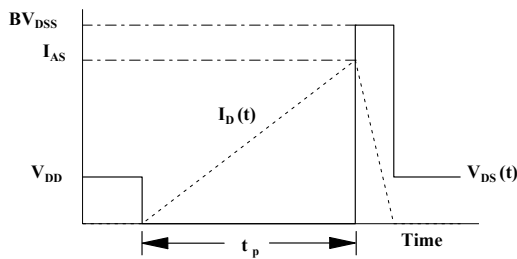
### Resistive Switching Test Circuit & Waveforms



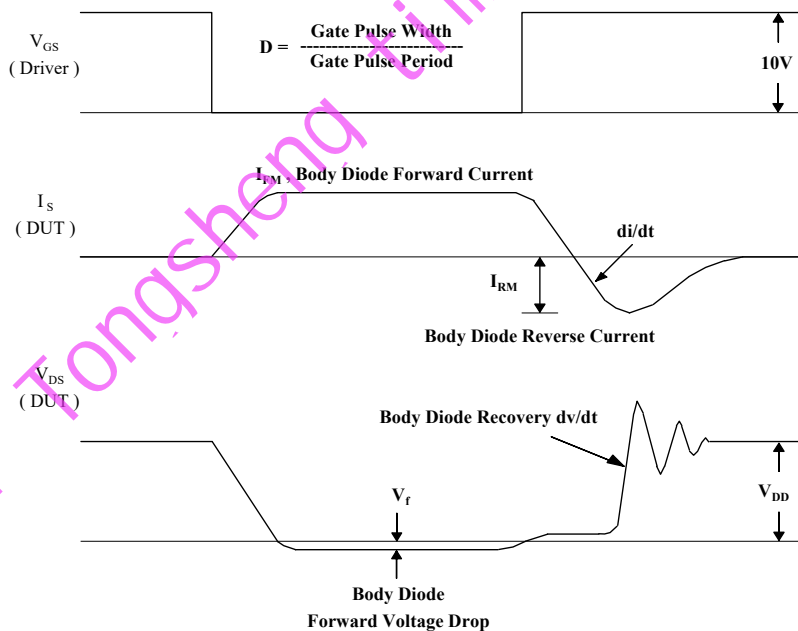
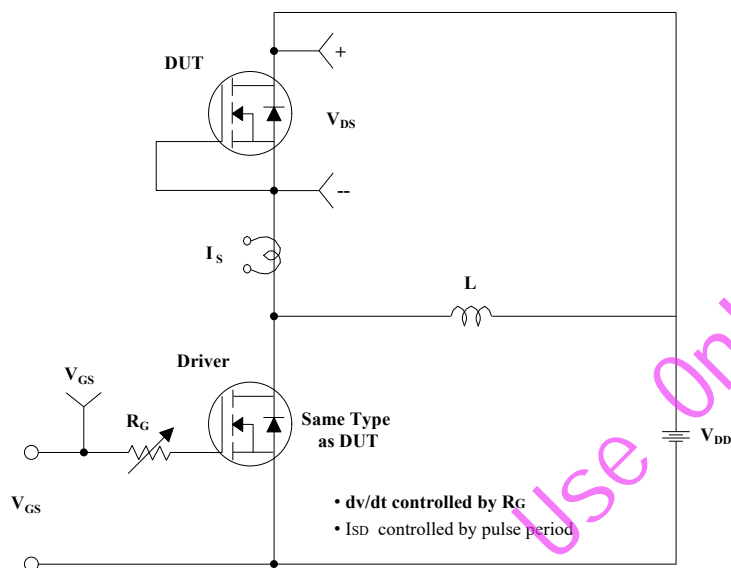
### Unclamped Inductive Switching Test Circuit & Waveforms



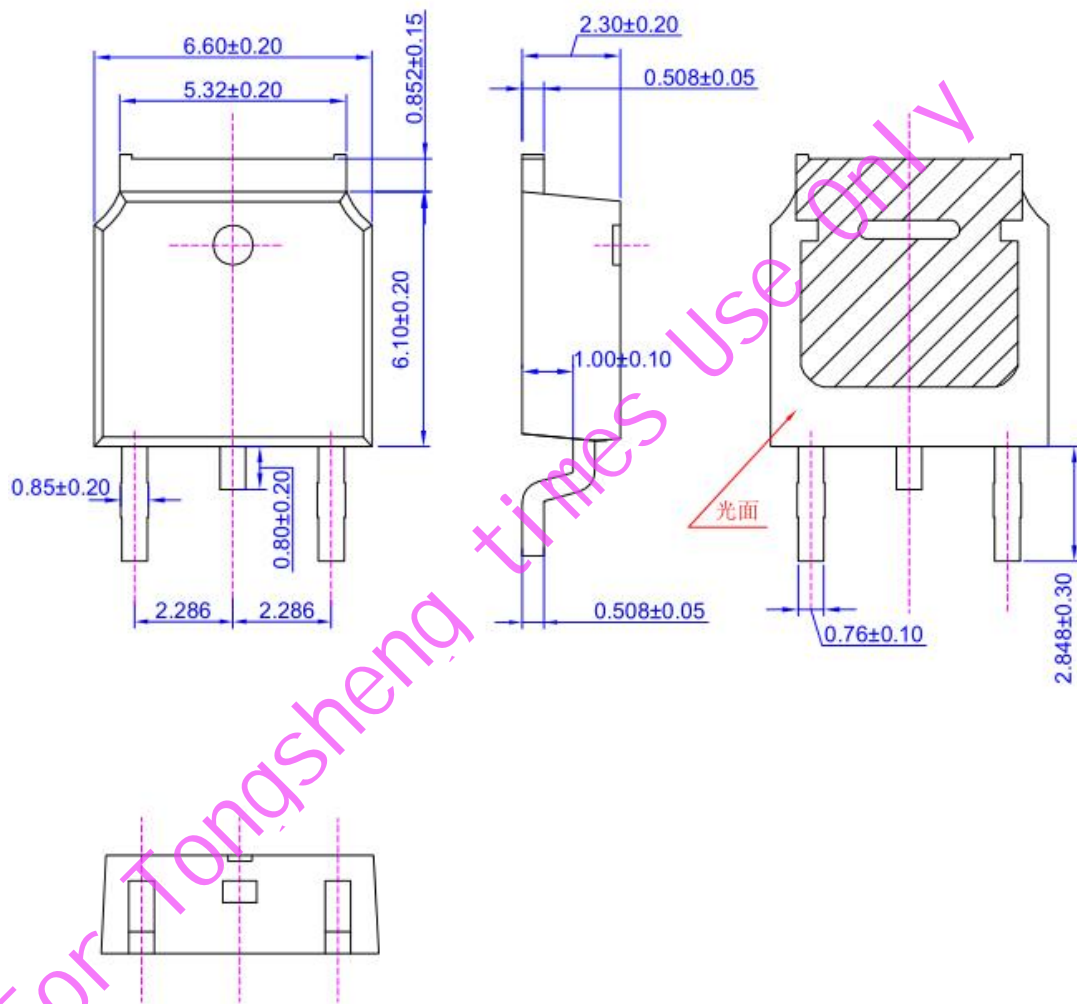
$$E_{AS} = \frac{1}{2} L_L I_{AS}^2 - \frac{BV_{DSS}}{BV_{DSS} - V_{DD}}$$



## Peak Diode Recovery dv/dt Test Circuit & Waveforms



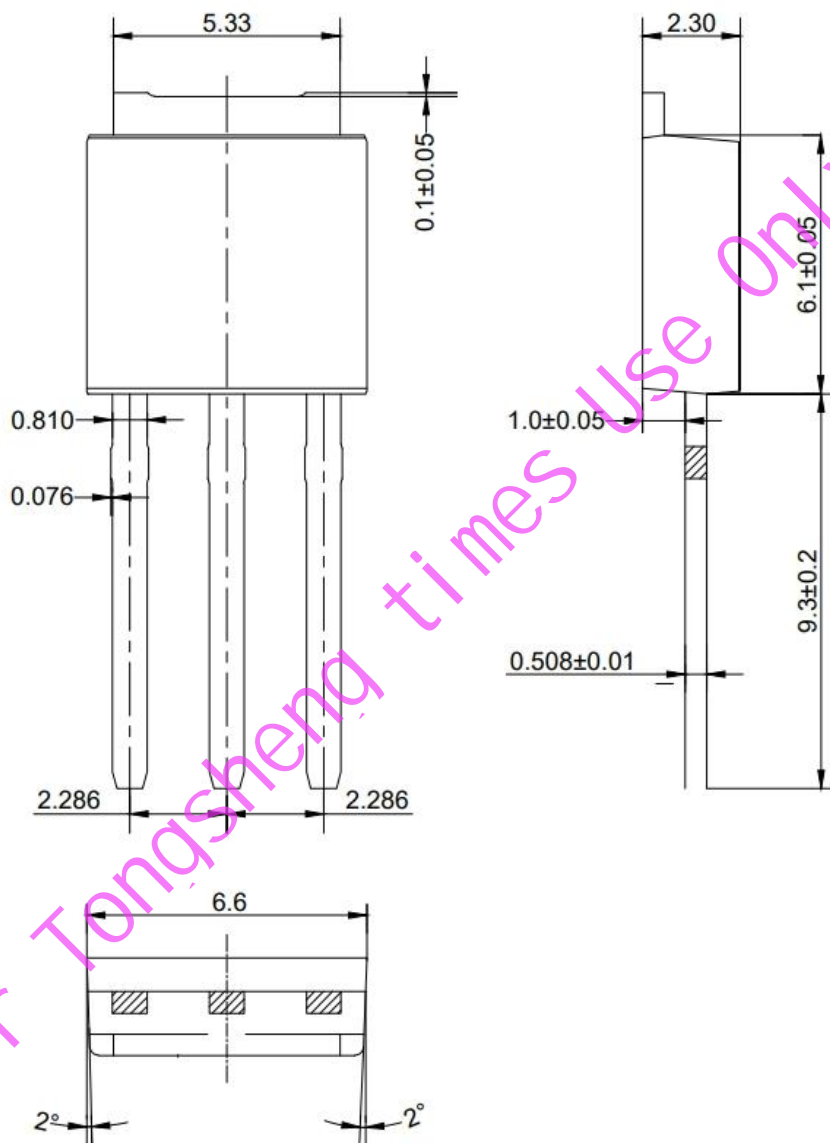
### TO-252 OUTLINE



**NOTE:**

- 1The plastic package is not marked as smooth surfaceRa=0.1;Subglossy surfaceRa=0.8
- 2.Undeclared tolerance  $\pm 0.25$ ,Unmarked filletRmax=0.25

### TO-251 OUTLINE



Note:

1,Unit: millimeters

2,The tolerance not noted is  $\pm 0.15$ , and the unmarked fillet  $R_{max} = 0.25$