



Ultrasoft Recovery Bridge



ABS Package

PINNING

PIN	DESCRIPTION
1	Input Pin (~)
2	Input Pin (~)
3	Output Anode (+)
4	Output Cathode (-)

Features

- Glass Passivated Chip Junction
- Reverse Voltage - 800 V
- Forward Current - 2 A
- High Surge Current Capability
- Designed For Surface Mount Application

Benefits

- Case: ABS
- Terminals: Solderable Per MIL-STD-750
- Approx. Weight: 82mg 0.0029oz

Maximum Ratings and Electrical characteristics

Ratings at 25 °C ambient temperature unless otherwise specified.

Single phase half-wave 60 Hz, resistive or inductive load, for capacitive load current derate by 20 %.

Parameter	Symbols	WRABS20KG	Units
Maximum Repetitive Peak Reverse Voltage	VRRM	800	V
Maximum RMS voltage	VRMS	560	V
Maximum DC Blocking Voltage	VDC	800	V
Average Rectified Output Current	Io	2	A
Reverse Recovery Time. IF=0.5A,IR=1A,IRR=0.25A	Trr	10	us
Peak Forward Surge Current 8.3 ms Single Half Sine Wave Superimposed on Rated Load (JEDEC Method)	IFSM	75	A
I ² t rating for fusing (1ms< t <8.3ms)	I ² t	23.3	A ² S
Maximum Forward Voltage at 1 A	VF	1.0	V
Maximum DC Reverse Current @TA=25 °C at Rated DC Blocking Voltage @TA=125 °C	IR	5 100	μA
Typical Junction Capacitance (Note1)	Cj	25	pF
Operating and Storage Temperature Range	Tj, Tstg	-55 ~ +175	°C
Typical thermal resistance (Note 2)	RthJC RthJA	16 60	°C/W

Note: 1. Measured at 1MHz and applied reverse voltage of 4 VDC.

2. Thermal resistance junction to case, lead and ambient in accordance with JESD-51.

Unit mounted on glass-epoxy substrate with 1oz/ft² 20x20 mm copper pad per pin with heatsink

RATINGS AND CHARACTERISTICS CURVES (TA = 25 °C unless otherwise noted)

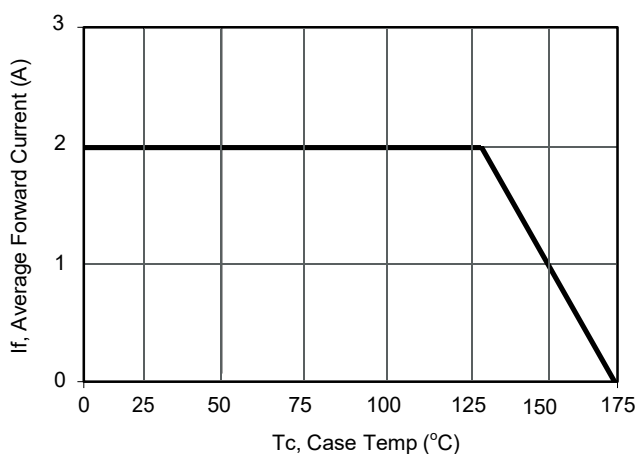

Current Derating, Case

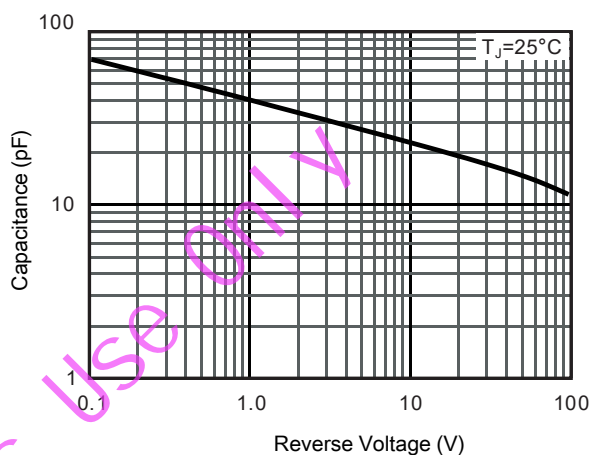

Typical Junction Capacitance

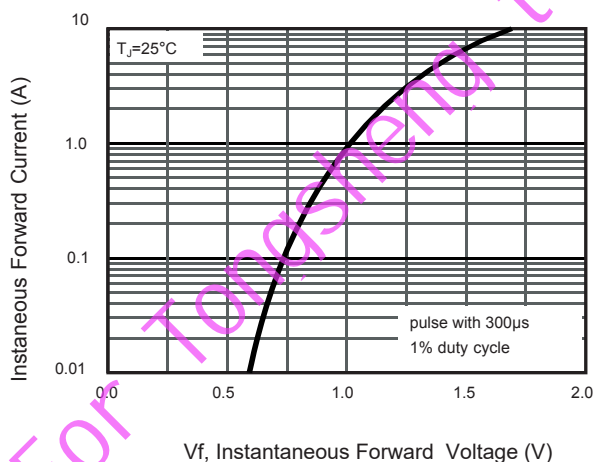

Typical Forward Voltage

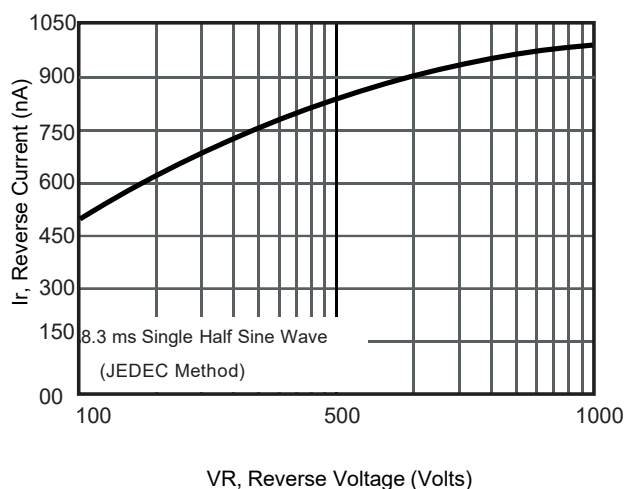

Typical Reverse Current



PACKAGE OUTLINE DIMENSIONS

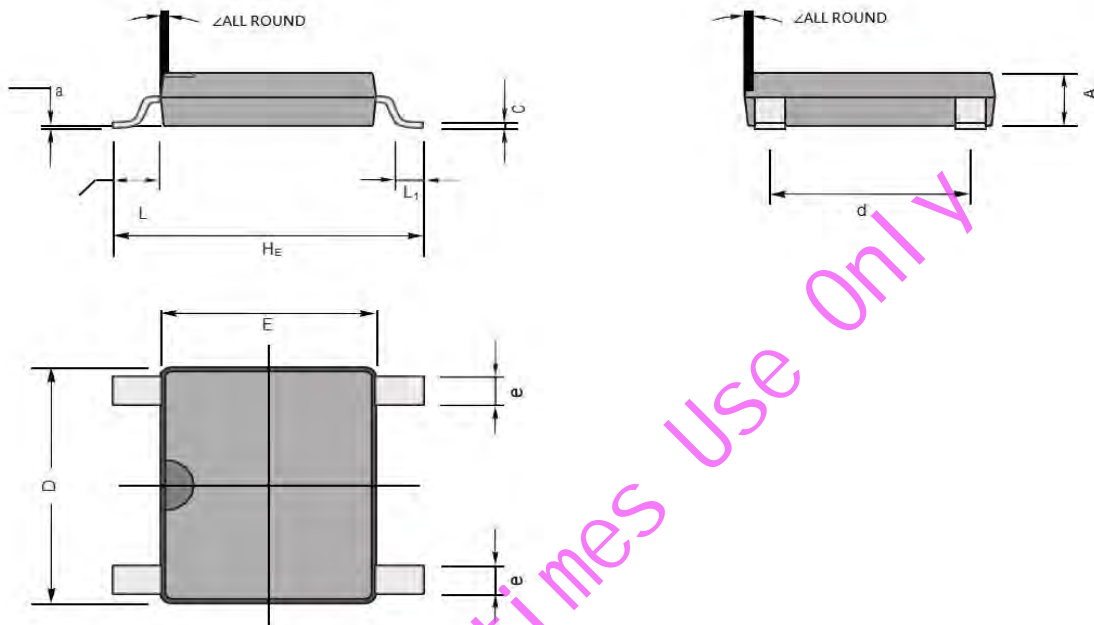

ABS mechanical data

Model		A	C	D	E	HE	d	e	L	L ₁	a	∠
WRABS 20KG	max	1.5	0.22	5.2	4.5	6.4	4.2	0.7	0.95	0.6	0.2	7°
	min	1.2	0.15	4.9	4.2	6.0	3.8	0.5				

Note:UNIT mm

ABS Suggested Pad Layout

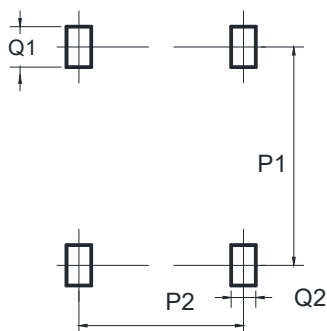

Dimensions is millimeters

UNIT		P1	P2	Q1	Q2
mm	min	5.70	4.00	1.0	0.9
mil	min	224.40	157.48	39.37	35.43



Soft-Bridge®

WRABS20KG

23-NOV-2021

Marking Information

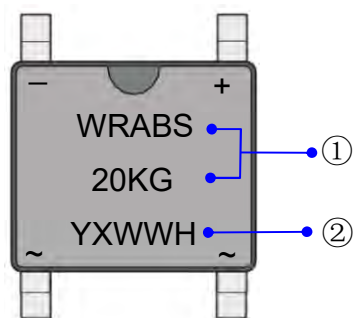

① Product model : WRABS20KG

② PDC information:

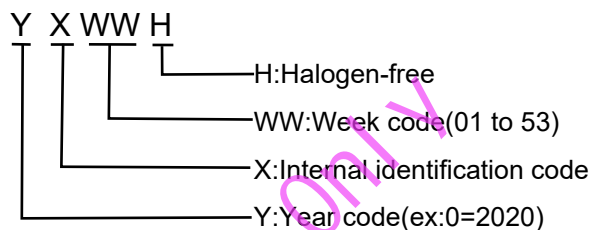

Packaging Information

1. Reel Dimensions

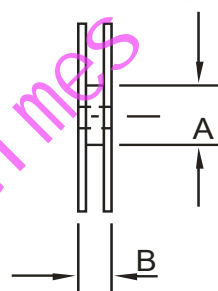
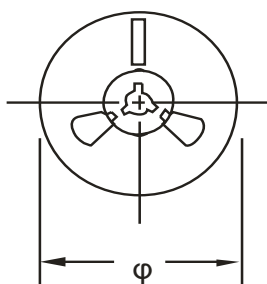

2. Inside Box

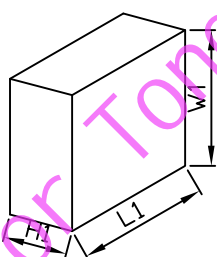

3. Outside Box

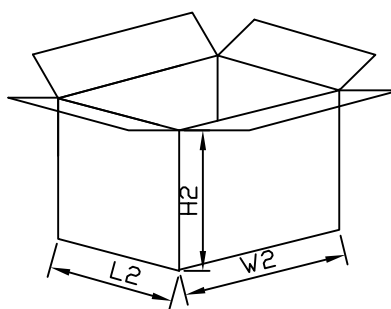

Packaging Information

NO	UNIT	Reel Dimensions			Inside Box			Outside Box		
		φ	A	B	L1	W1	H1	L2	W2	H2
Size	mm	330	100	15	335	335	43	360	360	270
QTY	PCS	Smallest package,5000PCS/reel			10,000PCS,2 reel in total			60,000PCS/carton,6boxes in total		
Note		Tolerance ≤20mm,±3mm;			21-100mm,±5mm;			101-500mm,±10mm		