

## Synchronous Rectification Driver with Green Mode Function

REV. 00

### General Description

LD8526 is a secondary side synchronous rectification (SR) driver IC. It is suited for flyback low side and high side synchronous rectification in CCM, DCM and QR mode. For forward freewheeling rectification application, LD8526 can be applied in CCM and DCM operation.

In light load condition, LD8526 will enter green mode to reduce operation current by stopping SR MOSFET driving function.

LD8526 can generate its own supply voltage through low output voltage or high side rectification applications to charge battery.

### Features

- Suited for low side and high side flyback synchronous rectification in CCM, DCM and QR(valley lock) mode
- Suited for forward freewheeling rectification in CCM and DCM
- Self-supplying for operation with low output voltage and/or high-side rectification without an auxiliary winding.
- Suited for primary side with peak load function (max. frequency 130kHz)
- Suited for PD application, which output voltage range from 3V to 21V, and VCC range from 3V to 6V.
- Programmable turn-off level
- Fast turn-off total delay of 30ns
- 200 $\mu$ A ultra-low green mode operation current
- Gate source/sink capability: 0.5A/-3A

### Applications

- Switching AC/DC adaptor and battery charger
- Open frame switching power supply

## Typical Application

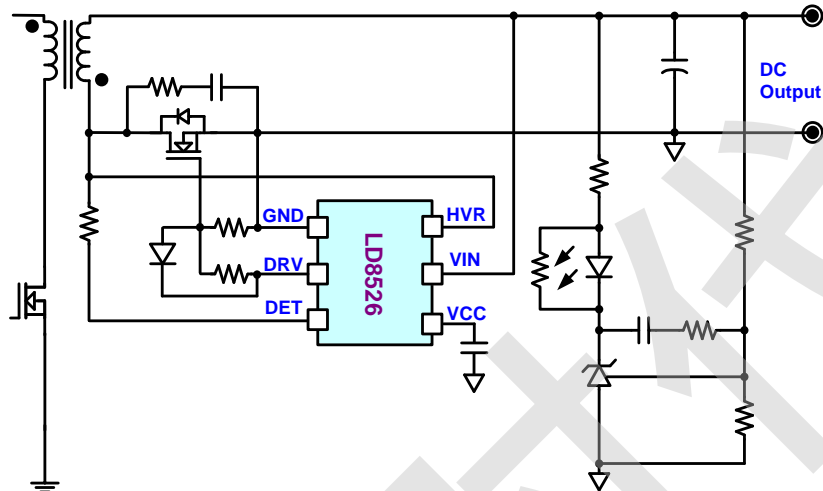

Fig. 1 Flyback Low Side Synchronous Rectification

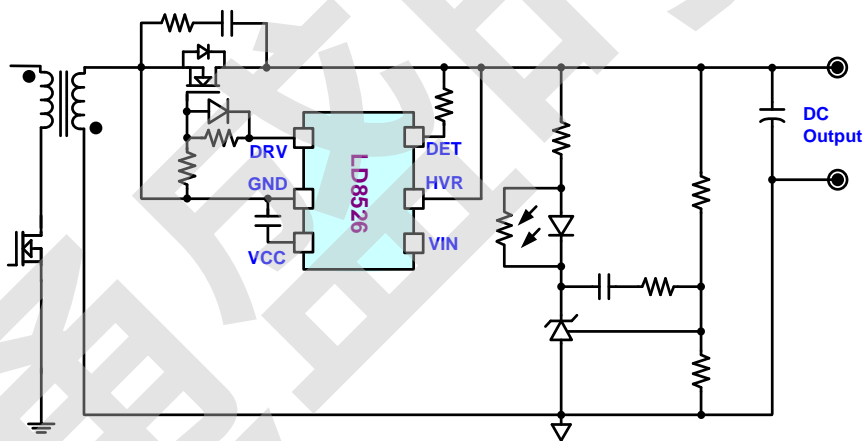
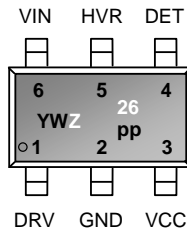

Fig. 2 Flyback High Side Synchronous Rectification

## Pin Configuration

SOT-26 (TOP VIEW)



Y : Year code (D: 2004, E: 2005.....)  
 W : Week code  
 PP : Production code  
 Z26 : LD8526

## Ordering Information

Part number	Package		Top Mark	Shipping
LD8526 GL	SOT-26	Green Package	YWZ/26	3000 / tape & reel

The LD8526 is ROHS compliant/ green packaged.

## Protection Mode

Part number	Int. OTP
LD8526	Auto-Restart

## Pin Description

PIN (SOT-26)	NAME	FUNCTION
1	DRV	Driving pin, connector to GATE pin of MOSFET directly or through a resistor
2	GND	Ground pin
3	VCC	Supply voltage pin
4	DET	Synchronous rectification detection
5	HVR	HV linear regulator input
6	VIN	External supply input

**Block Diagram**

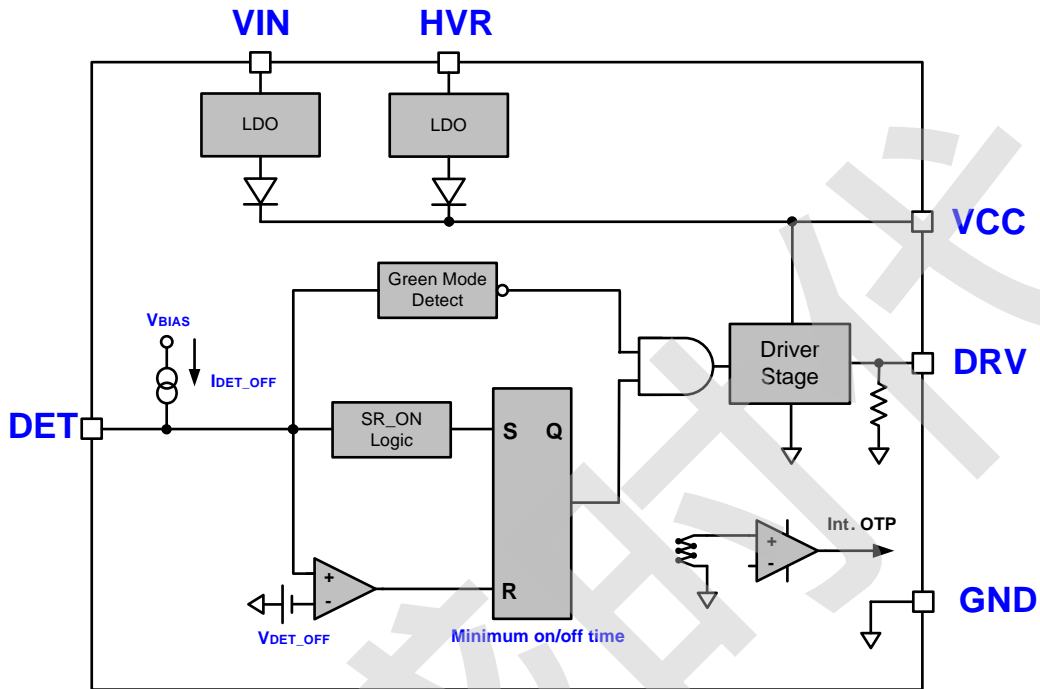

## Absolute Maximum Ratings

DET.....	-1V ~ 200V
HVR.....	-1V ~ 200V
VIN.....	-0.3V ~ 30V
VCC.....	-0.3V ~ 7V
DRV.....	-0.3V~VCC+0.3V
Maximum Junction Temperature.....	150°C
Storage Temperature Range.....	-65°C to 150°C
Package Thermal Resistance (SOT-26).....	200°C/W
Power Dissipation (SOT-26, at Ambient Temperature = 85°C).....	200mW
Lead temperature (Soldering, 10sec).....	260°C
ESD Voltage Protection, Human Body Model (except of DET/HVR Pin).....	2.5KV
ESD Voltage Protection, Human Body Model (DET/HVR Pin).....	1KV
ESD Voltage Protection, Machine Model.....	250V

### Caution:

Stresses beyond the ratings specified in “absolute maximum ratings” may cause permanent damage to the device. This is a stress only rating and operation of the device at these or any other conditions above those indicated in the operational sections of this specification is not implied.

## Recommended Operating Conditions

Item	Min.	Max.	Unit
Operating Junction Temperature	-40	125	°C
Supply Voltage VIN		24	V
Supply Voltage VCC	3	6	V
Power MOS Gate Threshold Voltage	1.5	4	V
Operating Frequency		130	KHz
VCC capacitor	2.2		μF
MOSFET Ciss <sup>(1)</sup>	1000	5500	pF
Turn-Off Rgate <sup>(1)</sup>	0	5	Ω
RDET		600	Ω

### Notes:

- When MOSFET Ciss is the maximum value, turn-off R<sub>GATE</sub> must be the minimum value. On the contrary, when MOSFET Ciss is the minimum, turn-off R<sub>GATE</sub> must be the maximum.

## Electrical Characteristics

(T<sub>A</sub> = +25°C unless otherwise stated, VIN=12V)

PARAMETER	CONDITIONS	SYMBOL	MIN	TYP	MAX	UNITS
<b>HVR (VIN Pin)</b>						
HVR charge current	HVR=30V, VCC=3.5V	I <sub>CHG_HVR1</sub>	20	35	50	mA
	HVR=12V, VCC=3.5V	I <sub>CHG_HVR2</sub>	10	20	30	mA
Leakage current	V <sub>HVR</sub> =200V	I <sub>HVR_LK</sub>			50	μA
<b>Supply Voltage (VIN Pin)</b>						
VIN charge current	VIN=12V, VCC=3.5V	I <sub>CHG_VIN</sub>	22	38	50	mA
<b>Supply Voltage (VCC Pin)</b>						
UVLO (on)		V <sub>CC_ON</sub>	2.8	3	3.2	V
UVLO (off)		V <sub>CC_OFF</sub>		2.8		V
UVLO Hysteresis		V <sub>CC_HYS</sub>		0.2		V
VCC Operating Voltage	HVR=12V	V <sub>VCC_H1</sub>	4.5	5.8	6.8	V
	VIN=12V	V <sub>VCC_H2</sub>	4.5	6.0	6.8	V
Operating Current	Vcc=5V, DET=65kHz, 4.7nF on GATE pin	I <sub>VCC_OP1</sub>		2.2	3	mA
	Green mode	I <sub>VCC_OP2</sub>		200	250	μA
	UVLO_OFF mode VCC=2.5v	I <sub>VCC_OFF</sub>		25		μA
<b>Detection Reference (DET Pin)</b>						
Turn-on voltage		V <sub>DET_ON</sub>	-400	-300	-150	mV
Turn-off voltage	(3)	V <sub>DET_OFF</sub>	10	20	30	mV
Turn-off compensation current		I <sub>DET_OFF</sub>	85	100	115	μA
Ring Reject Threshold		V <sub>DET_R</sub>	1.3	1.6	1.8	V
Ring Reject Threshold Hysteresis		V <sub>DET_RHY</sub>		1.1		V
Ring Reject Window		T <sub>DET_WD</sub>	50	70	100	ns
Leakage current	V <sub>DET</sub> =200V	I <sub>DET_LK</sub>			1	μA
Max. Operating Limit	(1)	F <sub>SW_MAX</sub>	150	180	220	kHz

PARAMETER	CONDITIONS	SYMBOL	MIN	TYP	MAX	UNITS
<b>Drive (DRV Pin)</b>						
Total Turn-on delay time	(2)	$T_{D\_ON}$		65		ns
Total Turn-off delay time	(2)	$T_{D\_OFF}$		25		ns
Pseudo dead time		$T_{PDT}$	4	5	6	$\mu$ s
Output High Voltage	$I_o=+10mA$	$V_{DRV\_H}$	4.4	4.7		V
Output Low Voltage	$I_o=-10mA$	$V_{DRV\_L}$			0.5	V
Turn-off propagation delay		$T_p$		15		ns
Turn-on Rising time	(2), drive voltage from 20%(2V) to 80%(8V)	$T_r$		75	150	ns
Turn-off Falling time	(2), drive voltage from 80%(4V) to 20%(1V)	$T_f$		13	30	ns
Minimum On Time		$T_{MIN\_ON}$		1.5		$\mu$ s
Minimum Off Time		$T_{MIN\_OFF}$	0.7	1	1.3	$\mu$ s
<b>On Chip OTP (Over Temperature) Auto-Recovery</b>						
OTP Level	(1)	$T_{OTP}$		150		$^{\circ}$ C
OTP Hysteresis	(1)	$T_{OTP\_HYS}$		30		$^{\circ}$ C

**Notes:**

1. Guaranteed by design.
2. Load capacitance=4.7nF.
3. For avoiding SR being too late to turn off in CCM,  $R_{DET}$  must be adjusted from 600R down to appropriate value.

**Typical Performance Characteristics**

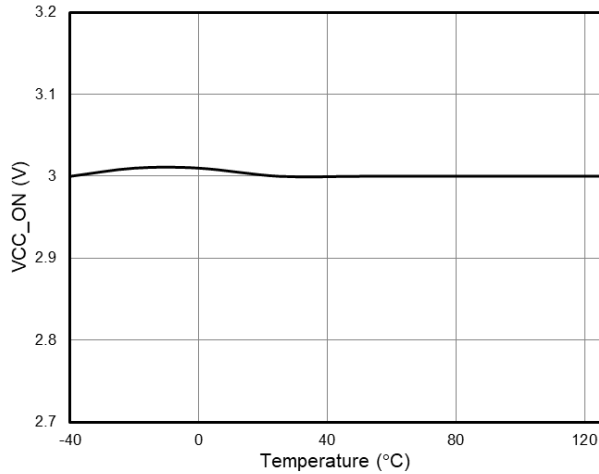

Fig. 3 UVLO ON vs. Temperature

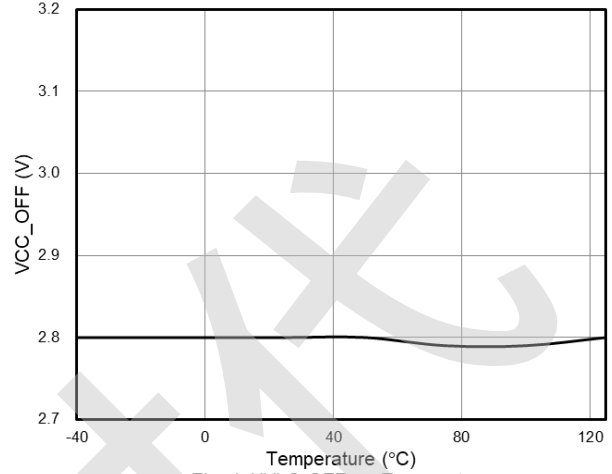

Fig. 4 UVLO OFF vs. Temperature

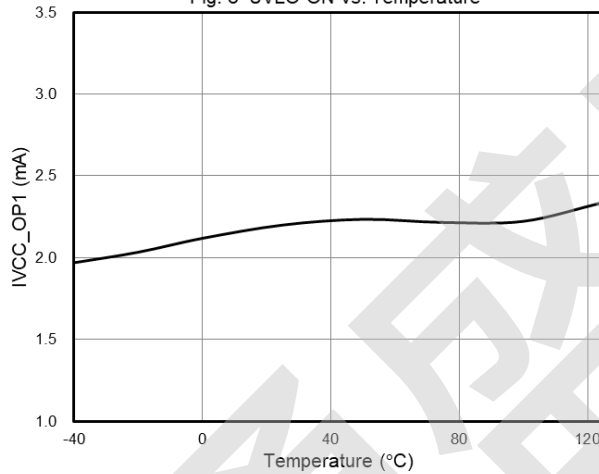

Fig. 5 Operation Current vs. Temperature

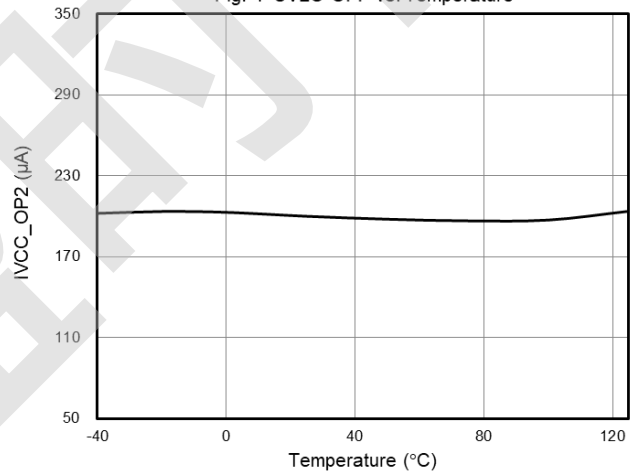

Fig. 6 Green Mode Current vs. Temperature

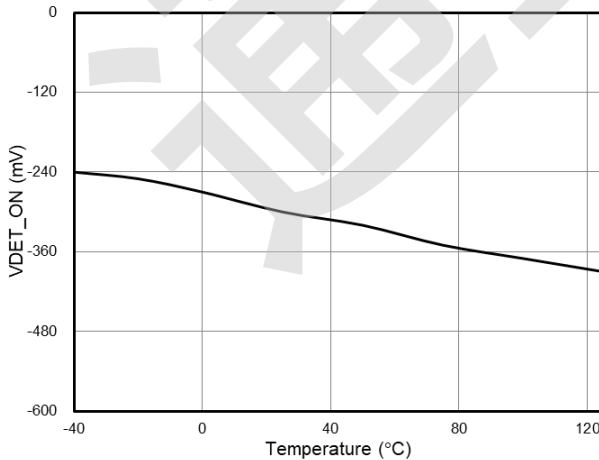

Fig. 7 Turn On Voltage vs. Temperature

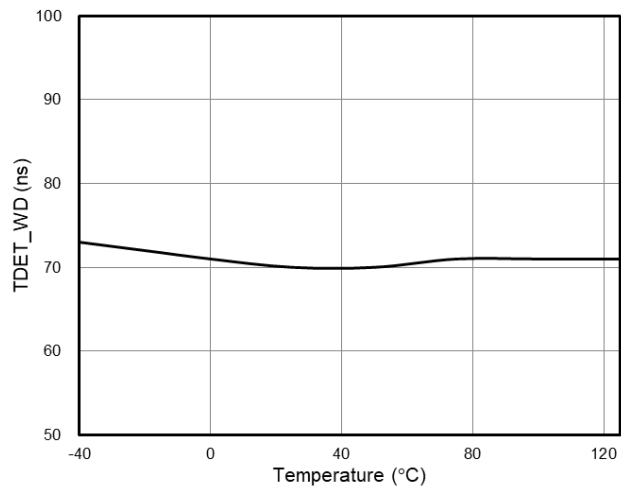

Fig. 8 Ring Reject Window vs. Temperature



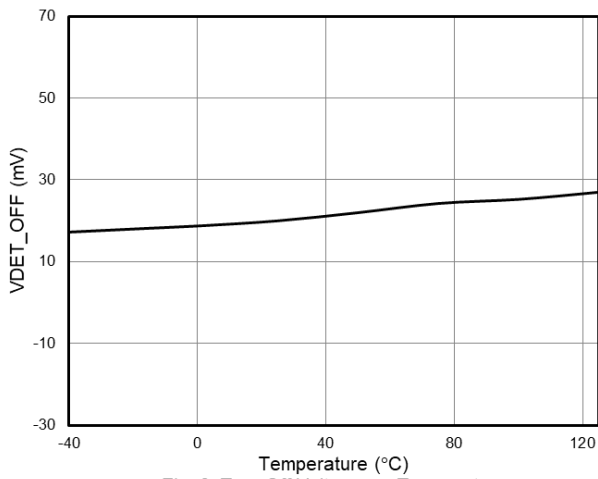

Fig. 9 Turn Off Voltage vs. Temperature

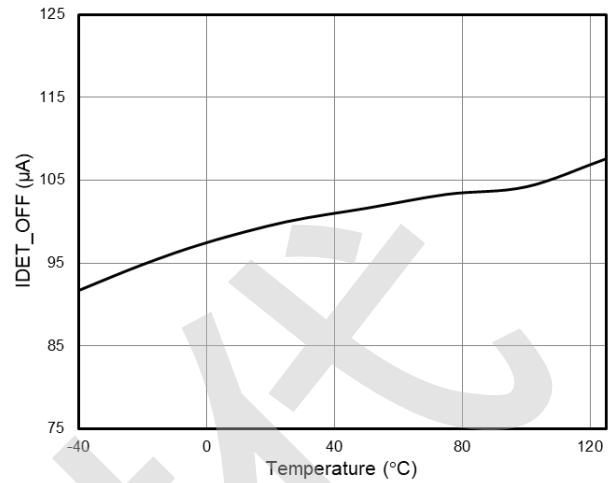

Fig. 10 Turn Off Compensation Current vs. Temperature

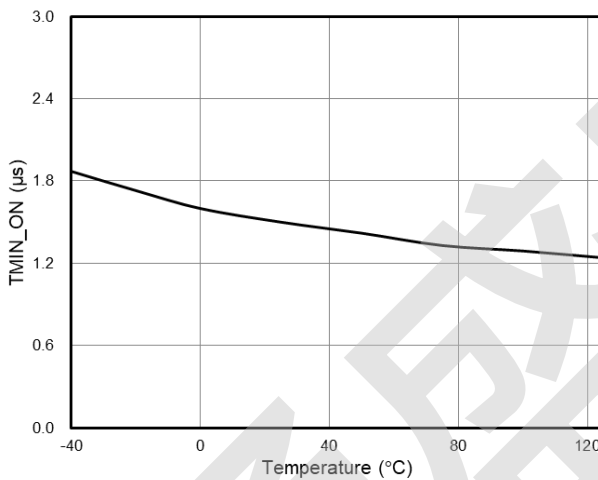

Fig. 11 Minimum On Time for LD8525 vs. Temperature

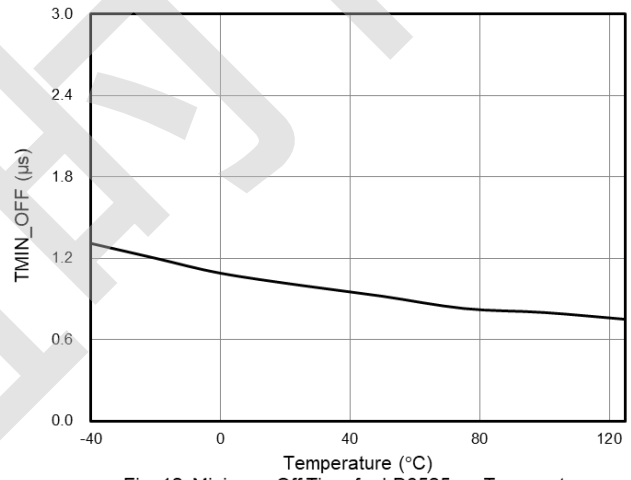

Fig. 12 Minimum Off Time for LD8525 vs. Temperature

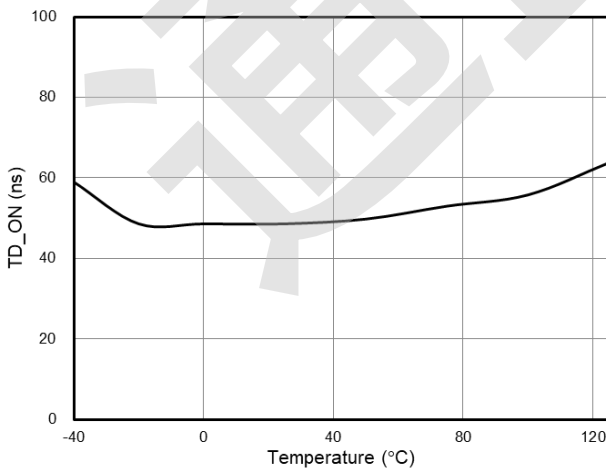

Fig. 13 Total Turn-On Delay Time vs. Temperature

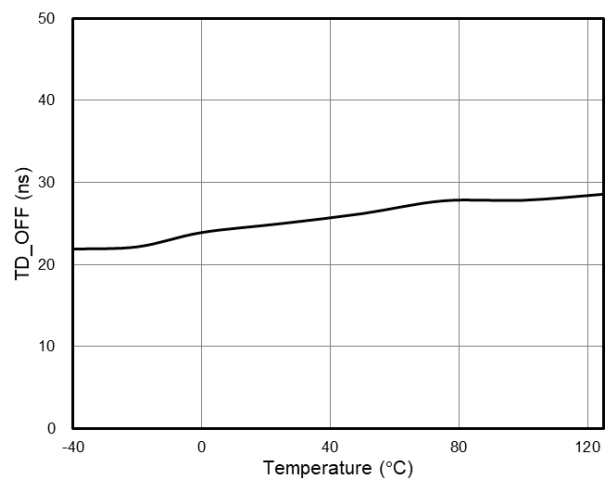

Fig. 14 Total Turn-Off Delay Time vs. Temperature

## Application Information

### Operation Overview

The LD8526 is a secondary side synchronous rectification driver IC for CCM and DCM operation. The LD8526 not only has excellent dead time control function for safety in load transient, but also only needs very low operation current in green mode. In addition, LD8526 can generate its own supply voltage through low output voltage or high side rectification applications to charge battery. Hence, LD8526 is suitable for PD application.

### LDO Charge Function

LD8526 has two LDO (low drop-out regulator), which are used to provide VCC power. When LD8526 is applied in low side, VIN is connected to DC output and HVR is connected to SR MOSFET drain pin. Once the primary side power on and DC output is below 4.4V, VCC will be charged by HVR via LDO and VCC will keep at 5.8V at heavy load. As DC output exceeds 4.4V, VCC will be replaced by VIN to charge via LDO. When VIN increases, VCC also rises until 5.2V.

When LD8526 is applied in high side, HVR is connected to SR MOSFET drain pin, too. However VIN is floating. VCC can only be charge by HVR via the LDO. And in heavy load, the VCC is always maintained at 5.8V.

No matter LD8526 is applied in high side or low side, a capacitor must exist from VCC to GND to store the energy.

### Under Voltage Lockout (UVLO) and Enable Function

An UVLO comparator is implemented in it to detect the voltage on the VCC pin. It will assure the supply voltage enough to turn on the LD8526 controllers and further to drive the synchronous rectifier. As shown in Fig. 15, the UVLO(ON) and UVLO(OFF) are 3V and 2.8V respectively.

To enable synchronous rectifier, the following conditions must be met:

1.  $VCC > UVLO(ON)$
2. Exit green mode
3.  $DET > V_{DET\_ON}$

With these restrictions, synchronous rectifier always operates in stable condition. Therefore, some unstable transient, which are like turn-on, turn-off, output short, surge, ESD...etc., will not make synchronous rectifier unsafe when it works.

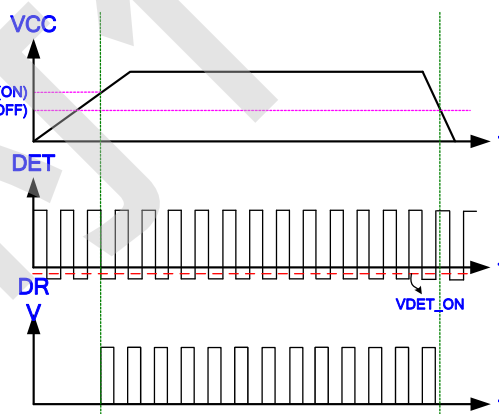

Fig. 15

### Green Mode Operation

For improving the efficiency in light load conditions, LD8526 stops SR MOSFET driving function to reduce operation current, as shown in Fig. 16.

DET pin detects system behavior, and the internal logic circuit sets DRV to high or low. Hence, LD8526 can enter/exit green mode normally, even under dynamic load.

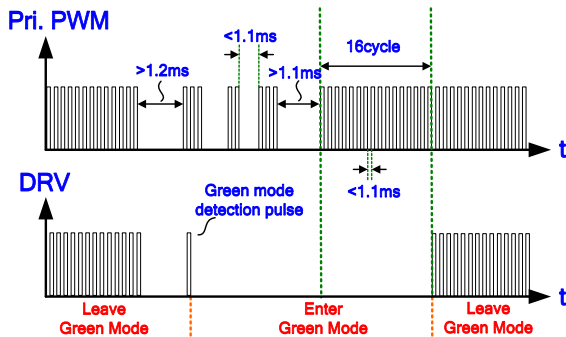

Fig. 16

## Turn-on Phase

After a negative voltage (-300 mV typical) is sensed on the DET pin, the driver output voltage (Int. DRV, see Block Diagram) is made high and the internal MOSFET is switched on. After switch-on of the SR MOSFET, the input signal on the DET pin is blanked for 1.5μs (typical). This will eliminate false switch-off due to high frequency ringing at the start of the secondary stroke.

## Turn-off Phase

The DET pin has detection gate on time to do prediction gate pre-drop method ( $T_{ON} \times 0.5 = T_{PREDICT}$ ), and adjusting  $V_{DS}$  decreases gate driver voltage to 4V (typical).

As soon as the DET voltage is above  $V_{DET\_OFF}$ , the driver output is pulled to ground. For avoiding SR being too late to turn off in CCM, the following condition must be met, as shown in Fig. 17.

$$V_{DET\_OFF} - I_{DET\_OFF} \times R_{DET} + X = -10mV$$

Where  $I_{DET\_OFF} = 100\mu A$ ,  $V_{DET\_OFF} = +20mV$ ,  $X =$  thermal effect and parasitic inductance from trace & electronic components. Hence  $R_{DET}$  must be from  $600\Omega$  down to find the appropriate turn-off time.

The behavior of Int. DRV in DCM & CCM are shown separately in Fig. 18.

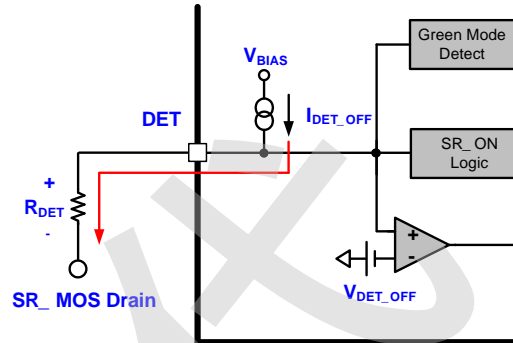

Fig. 17

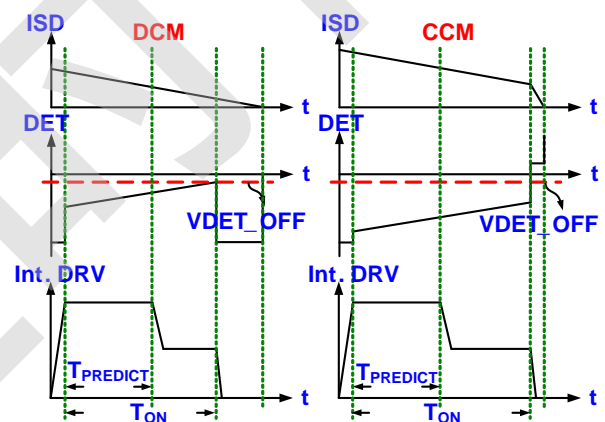

Fig. 18

## On-Chip OTP - Auto Recovery

An internal OTP circuit is embedded inside the LD8526 to provide the worst-case protection for this controller. When the chip temperature rises and it's higher than the trip OTP level, the output will be disabled until the chip is cooled down below the hysteresis window.

## Package Information

SOT-26

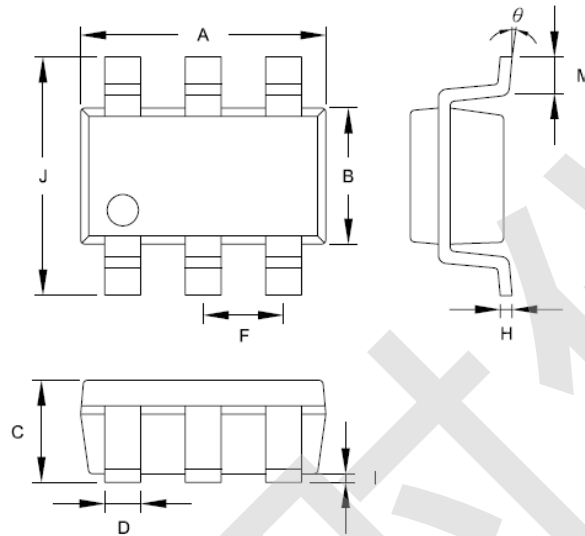

Symbol	Dimension in Millimeters		Dimensions in Inches	
	Min	Max	Min	Max
A	2.692	3.099	0.106	0.122
B	1.397	1.803	0.055	0.071
C	-----	1.450	-----	0.057
D	0.300	0.500	0.012	0.020
F	0.95 TYP		0.037 TYP	
H	0.080	0.254	0.003	0.010
I	0.050	0.150	0.002	0.006
J	2.600	3.000	0.102	0.118
M	0.300	0.600	0.012	0.024
θ	0°	10°	0°	10°

### Important Notice

Leadtrend Technology Corp. reserves the right to make changes or corrections to its products at any time without notice. Customers should verify the datasheets are current and complete before placing order.

**Revision History**

REV.	Date	Change Notice
00	08/31/2018	Original Specification

通盛时代